



GPPH PRODUCTS

2025

www.gpph-group.com



TABLE OF CONTENTS

WELDING TABLES - TRADITIONAL	5
WELDING TABLES - STAINLESS	15
WELDING TABLES - ECONOMIC VERSION	23
WELDING TABLES - MODULAR	31
WELDING TABLES - WELDING & ASSEMBLY TABLES	37
WELDING TABLES - OCTAGONAL	45
WELDING TABLES - LIFTING (with hydraulic lifting system)	49
WELDSTATION	55
SET OF DRAWERS AND BOTTOM SHELF	59
GRINDING-WELDING STATION	65
WELDING SUPPORTS	69
WELDING BLOCKS	77
WELDING TABLE CONNECTORS	83
RAIL SYSTEMS	87
GPPH IQ AIR FLOW - WELDING HOOD	97
GPPH IQ AERO CLEAN - FILTERING AND VENTILATION EQUIPMENT	101
WELDING GATE - GATEWAY FOR COBOTS	107
WELDING TOOLS	111
TOOL TROLLEYS	129
TOOLKITS	133
WELDING CHEMICALS	143
ABOUT US	144

SYMBOLS OF THE MOUNTING HOLE SYSTEM:



mounting holes every 100 mm



diagonally arranged mounting holes



mounting holes at 50 mm intervals



mounting holes with a diameter of 16 mm



mounting holes with a diameter of 28 mm

*Prices shown in the offer are net prices.

**Pictures and visualizations shown in the offer are for reference only. Colors and shades of some elements may differ from the real ones.

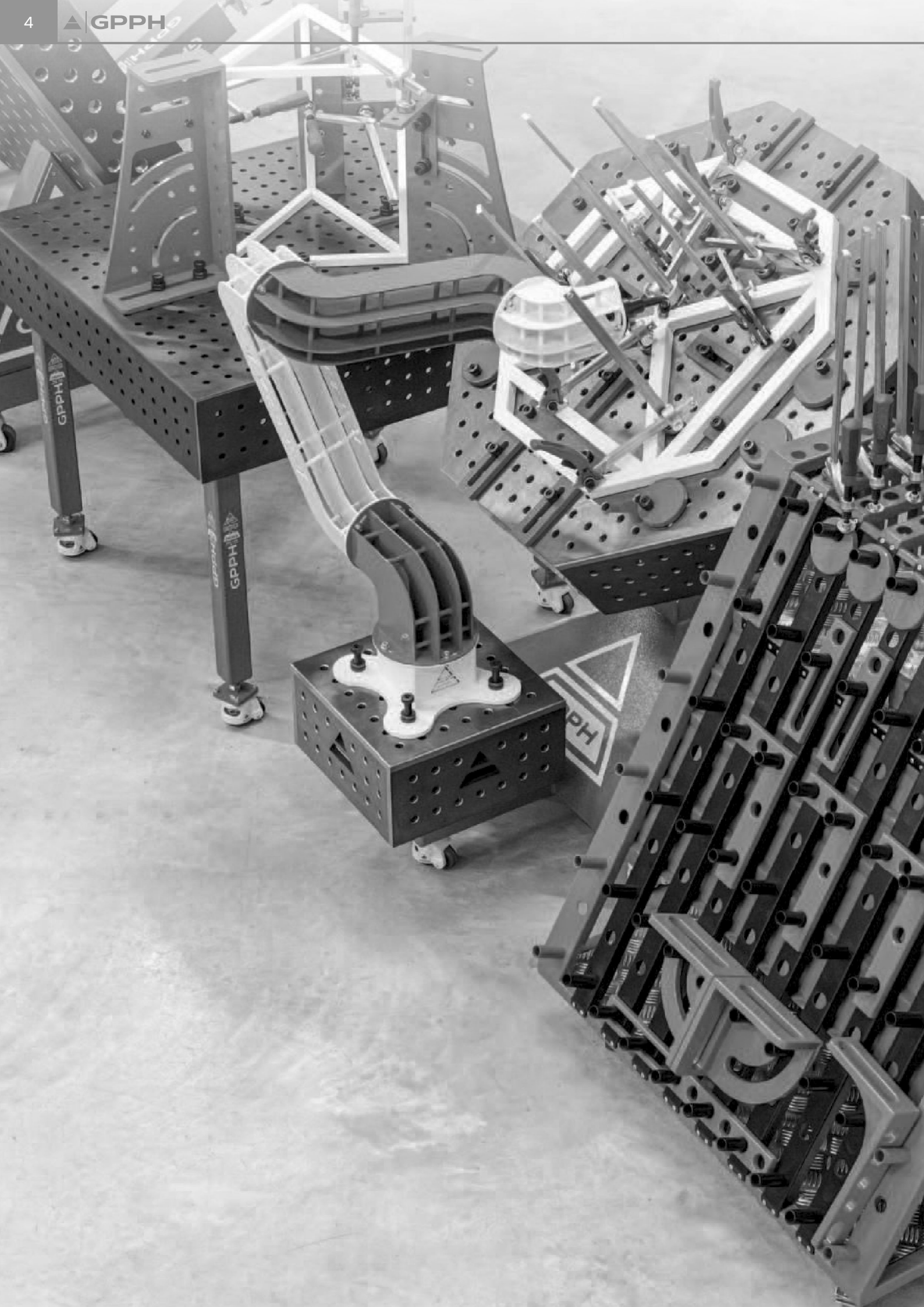

WELDING TABLES - TRADITIONAL



WELDING TABLES – TRADITIONAL

EXPERT, PRO, PLUS and ECO series

TECHNICAL PARAMETERS

The **EXPERT** series is a guarantee of performance and durability in any application. The load capacity of this model reaches an impressive 1000 kg per leg, making it the ideal partner for working with large and heavy structures. The 25 mm thick table top with 10 mm thick dense ribbing is a solid base, ensuring stability and resistance to deformation.

The **EXPERT** series welding table was primarily designed for heavy structures. It is ideal for the manufacture of heavy road, construction machinery and cranes. It will work well in the shipbuilding industry and in the production of railroad cars or heavy trailers. It will be perfect for advanced, heavy welding and metalworking projects where exceptional strength and precision are required.

For dedicated tools for **EXPERT** tables, see page 112.

The **EXPERT** welding table is not only a working tool, but also a way to optimize production processes. The precision-machined work surface makes it easier to set up and assemble parts, which speeds up subsequent work steps. Thanks to the stability and accuracy of the worktop, the risk of errors is reduced, and work becomes more intuitive and less demanding in terms of constant adjustments. This translates into greater efficiency and time savings, and in the long run also means lower operating costs. For companies with large projects, EXPERT is becoming a key element in increasing production efficiency.

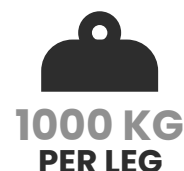

EXPERT



WELDING TABLES – TRADITIONAL

EXPERT, PRO, PLUS and ECO series

GPPH welding tables are synonymous with durability, precision and reliability. For years, we have been providing solutions that meet the highest demands of professionals, providing a stable and durable work surface in any working environment. Whether for lightweight construction or intensive loads, our tables guarantee safety and longevity of use.

The best proof of their exceptional durability is provided by the example of the **EXPERT** series tables, which, together with **TRESTLE** supports, have been subjected to an extreme test. In the photo you can see a bulldozer weighing several tons placed directly on their surface – a clear proof that our tables can cope even in the most demanding conditions. Robust construction and top-quality materials make GPPH welding tables an investment in reliability and safety.

A video of this project, demonstrating the stability and durability of our welding tables, can be seen by scanning the QR code.



WATCH
THE VIDEO!

#make
WELDING
SIMPLE
again



WELDING TABLES – TRADITIONAL

EXPERT, PRO, PLUS and ECO series

TECHNICAL PARAMETERS



GPPH's traditional welding tables come in four series: **EXPERT**, **PRO**, **PLUS** and **ECO**. Each of them is in as many as 10 dimensional versions.

You will use them wherever you need **precision when welding**. You will use them for manual or robotized welding. **Your constructions will finally be made accurately, without unnecessary corrections!**

They also provide ergonomic and fast work with precision and repeatability of the performed constructions.

The tables are made of S355J2+N material in accordance with **ISO 2768-1**.



All tables come in the version with legs on feet or on wheels.



HOLE AND GRID SYSTEMS OF TRADITIONAL WELDING TABLES:

	PRO	PLUS	ECO
GRID	HOLE SYSTEM		
	Ø 28 mm		Ø 16 mm
	100 x 100		50 x 50
	DIAGONAL		100 x 100
	DIAGONAL		DIAGONAL

	EXPERT
GRID	HOLE SYSTEM
	Ø 28 mm
	100 x 100
	DIAGONAL

WELDING TABLES – TRADITIONAL

EXPERT, PRO, PLUS and ECO series

TECHNICAL PARAMETERS

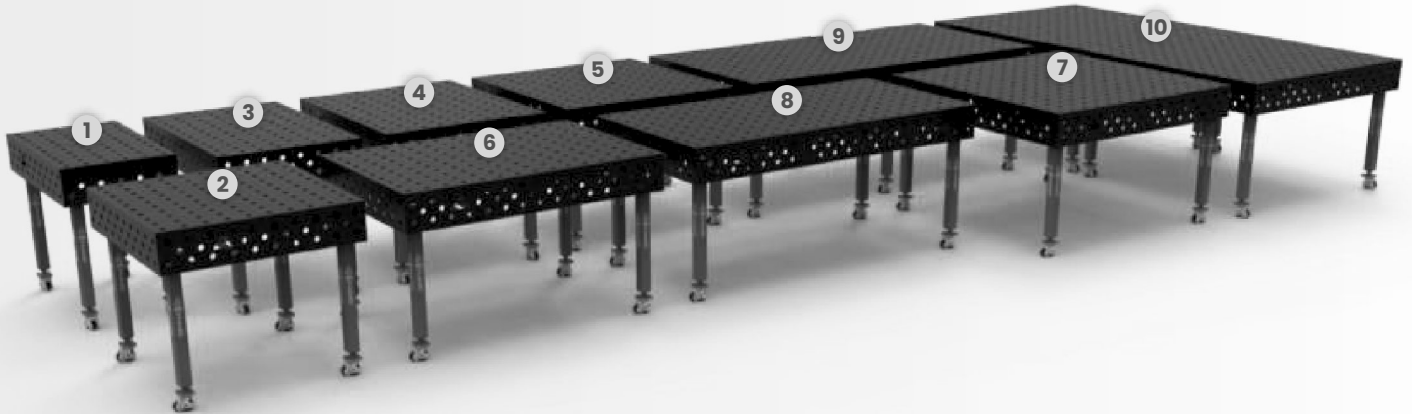

DIMENSIONS OF **EXPERT, PRO, PLUS** and **ECO** TABLES [mm].

1	1000 x 600	6	1500 x 1000
2	1000 x 1000	7	1500 x 1480
3	1200 x 800	8	2000 x 1000
4	1200 x 1000	9	2400 x 1200
5	1200 x 1200	10	3000 x 1480*

*The 3000x1480 GPPH welding table consists of two interconnected 1500x1480 GPPH welding tables.

LOAD CAPACITY AND LEG DIMENSIONS IN EACH SERIES:

EXPERT

120 x 120 mm



1000 KG
PER LEG

PRO

100 x 100 mm



700 KG
PER LEG

PLUS

80 x 80 mm



500 KG
PER LEG

ECO

60 x 60 mm



250 KG
PER LEG



WELDING TABLES – TRADITIONAL

EXPERT, PRO, PLUS and ECO series

TECHNICAL PARAMETERS

DIFFERENCES BETWEEN WELDING TABLE SERIES:

PARAMETER	EXPERT	PRO	PLUS	ECO
Flatness tolerance of the table (over the entire tabletop)*	±0,3 mm	±0,3 mm	±0,3 mm	±0,5 mm
3 rows of holes in the side wall	✓	✓	✓	✓
Thickness of the table top	25 mm	15 mm	12 mm	8 mm
Chamfered / milled holes	✓	✓	✓	✗
Chamfered holes on the underside	✓	✓	✓	✗
Tolerance of hole workmanship	+0,05 mm	+0,05 mm	+0,05 mm	±0,1 mm
Leg profile	120x120x4 mm	100x100x4 mm	80x80x4 mm	60x60x4 mm
Carrying capacity	1000 kg / leg	700 kg / leg	500 kg / leg	250 kg / leg
Total load capacity for table with 4 legs	4 000 kg	2 800 kg	2 000 kg	1 000 kg
Total load capacity for table with 6 legs	6 000 kg	4 200 kg	3 000 kg	1 500 kg
Total load capacity for table with 8 legs	8 000 kg	5 600 kg	4 000 kg	2 000 kg
Milled edges of the tabletop	✓	✓	✓	✗
Number of dimensional versions	10 versions	10 versions	10 versions	10 versions
Table height	880–930 mm	880–930 mm	880–930 mm	880–930 mm

*Provided the table is properly leveled.

All tables have **dense ribbing**, which contributes to a perfectly flat working surface. The ribs are spaced every 400 mm on average.

The massive and rigid base of the table top guarantees the highest stability during use and protection against deformation. The side walls of the tables have a height of 200 mm and are made with a deviation tolerance of ±0.3°.

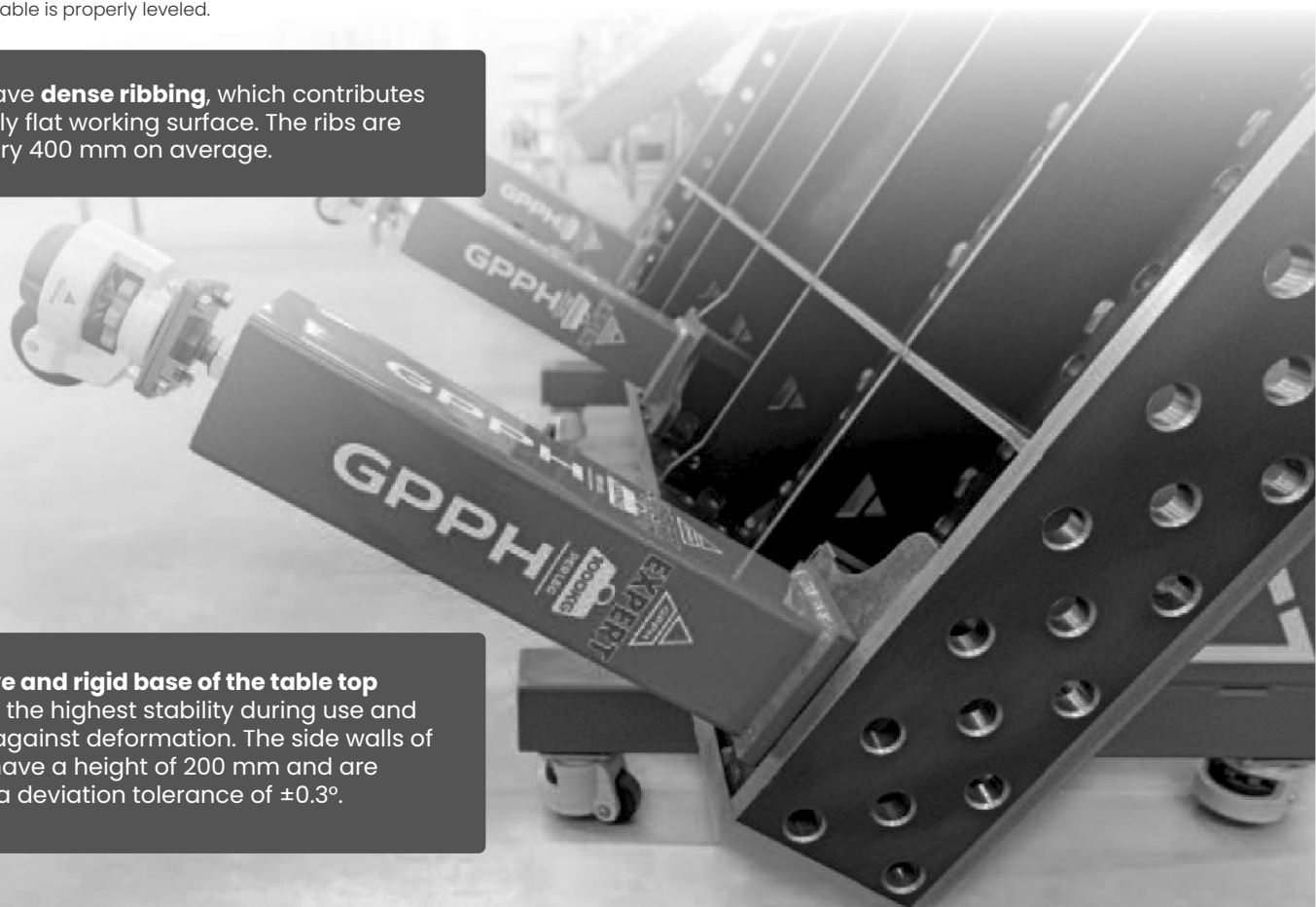

WELDING TABLES – TRADITIONAL

EXPERT, PRO, PLUS and ECO series

TECHNICAL PARAMETERS

Each table top has an **engraved scale** - these are vertical and horizontal lines in a 100x100 mm grid. It is a reference point when laying out the structure and when assembling tools. Using measuring tools, you can adjust your structure accordingly to get the dimension you need.

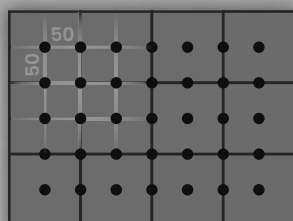

Ø 16 50x50

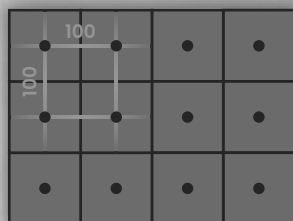

Ø 16 100x100

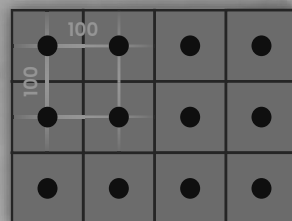

Ø 28 100x100

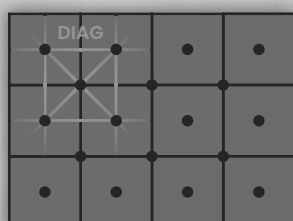

Ø 16 DIAGONAL

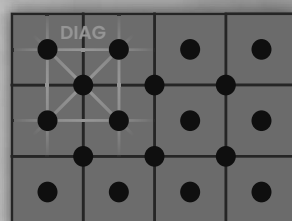

Ø 28 DIAGONAL

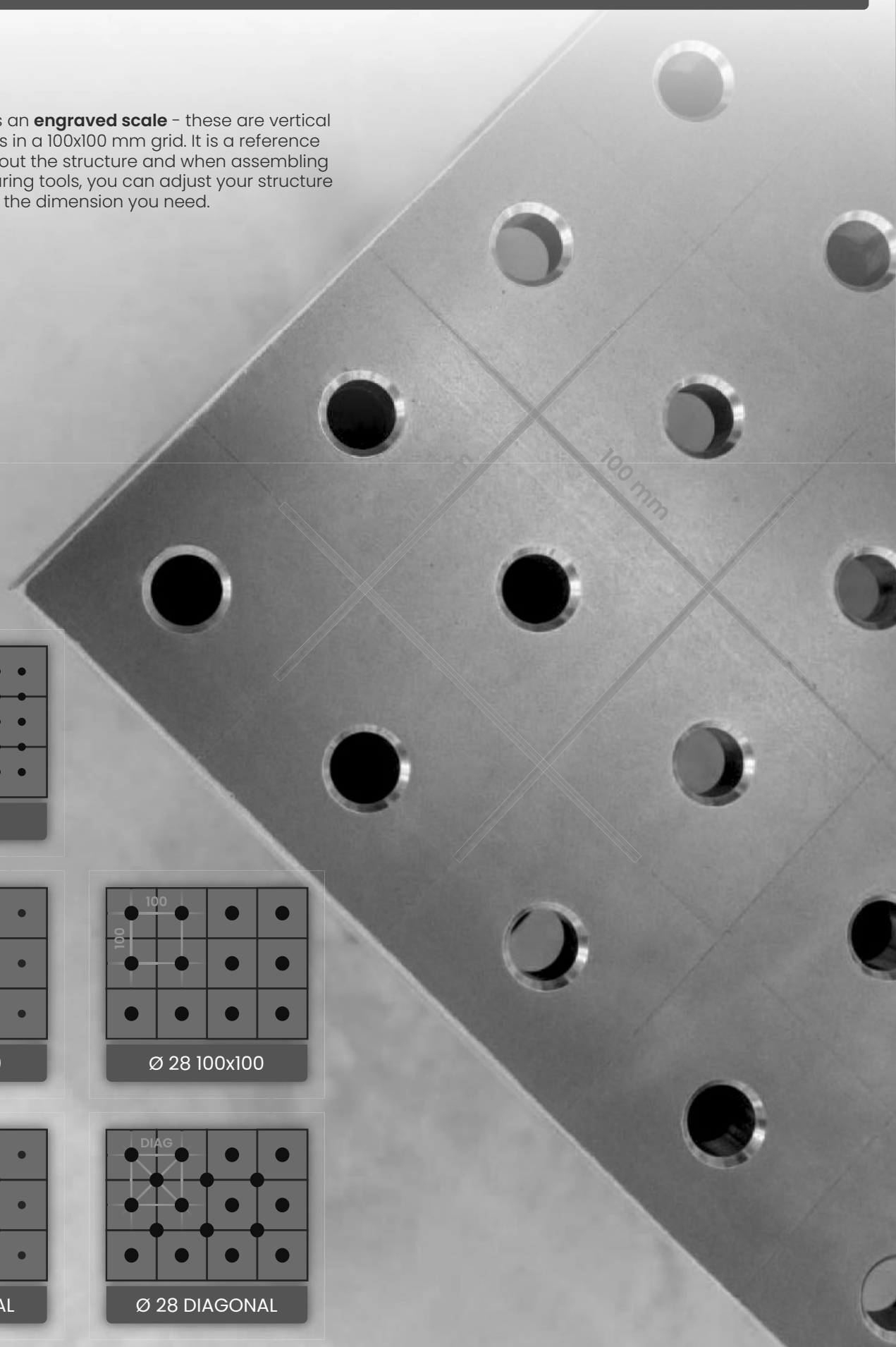

WELDING TABLES – TRADITIONAL

EXPERT, PRO, PLUS and ECO series – tables with legs on feet





DIMENSIONS AND PRICE LIST

Price list for tables with legs on feet with \varnothing 28 mm and \varnothing 16 mm hole system in 100x100 mm grid:



DIMENSIONS [mm]				
	EXPERT	PRO	PLUS	ECO
1000 x 600				
1000 x 1000				
1200 x 800				
1200 x 1000				
1200 x 1200				
1500 x 1000				
1500 x 1480				
2000 x 1000				
2400 x 1200				
3000 x 1480				

Pricing for tables with feet with \varnothing 28 mm and \varnothing 16 mm hole system in diagonal grid and for tables with \varnothing 16 mm hole system in 50x50 mm grid:

DIMENSIONS [mm]					
	EXPERT	PRO	PLUS	ECO	
1000 x 600					
1000 x 1000					
1200 x 800					
1200 x 1000					
1200 x 1200					
1500 x 1000					
1500 x 1480					
2000 x 1000					
2400 x 1200					
3000 x 1480					



WELDING TABLES – TRADITIONAL

EXPERT, PRO, PLUS and ECO series – tables with legs on wheels

DIMENSIONS AND PRICE LIST

Price list for tables with legs on wheels with Ø 28 mm and Ø 16 mm hole system in 100x100 mm grid:

DIMENSIONS [mm]	 	 		 	
	EXPERT	PRO	PLUS	ECO	
1000 x 600					
1000 x 1000					
1200 x 800					
1200 x 1000					
1200 x 1200					
1500 x 1000					
1500 x 1480					
2000 x 1000					
2400 x 1200					
3000 x 1480					

Price list for tables with legs on wheels with Ø 28 mm and Ø 16 mm hole system in diagonal grid and for tables with Ø 16 mm hole system in 50x50 mm grid:

DIMENSIONS [mm]	 	 		 		 	
	EXPERT	PRO	PLUS	ECO			
1000 x 600							
1000 x 1000							
1200 x 800							
1200 x 1000							
1200 x 1200							
1500 x 1000							
1500 x 1480							
2000 x 1000							
2400 x 1200							
3000 x 1480							

WELDING TABLES – TRADITIONAL

EXPERT, PRO, PLUS and **ECO** series – stainless steel covers





WYMIARY I CENNIK

You can buy a 1 mm thick **stainless steel overlay** for each **EXPERT, PRO, PLUS** and **ECO** series welding table.

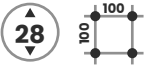
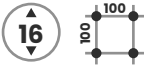
To transform a Traditional GPPH Welding Table into a table that is ideal for welding stainless steel, all you have to do is put the overlay on it.

The hole patterns of the stainless steel overlay are the same as those of the GPPH welding tables.

 	
DIMENSIONS [mm]	NET PRICE
1000 x 600	
1000 x 1000	
1200 x 800	
1200 x 1000	
1200 x 1200	
1500 x 1000	
1500 x 1480	
2000 x 1000	
2400 x 1200	

    	
DIMENSIONS [mm]	NET PRICE
1000 x 600	
1000 x 1000	
1200 x 800	
1200 x 1000	
1200 x 1200	
1500 x 1000	
1500 x 1480	
2000 x 1000	
2400 x 1200	

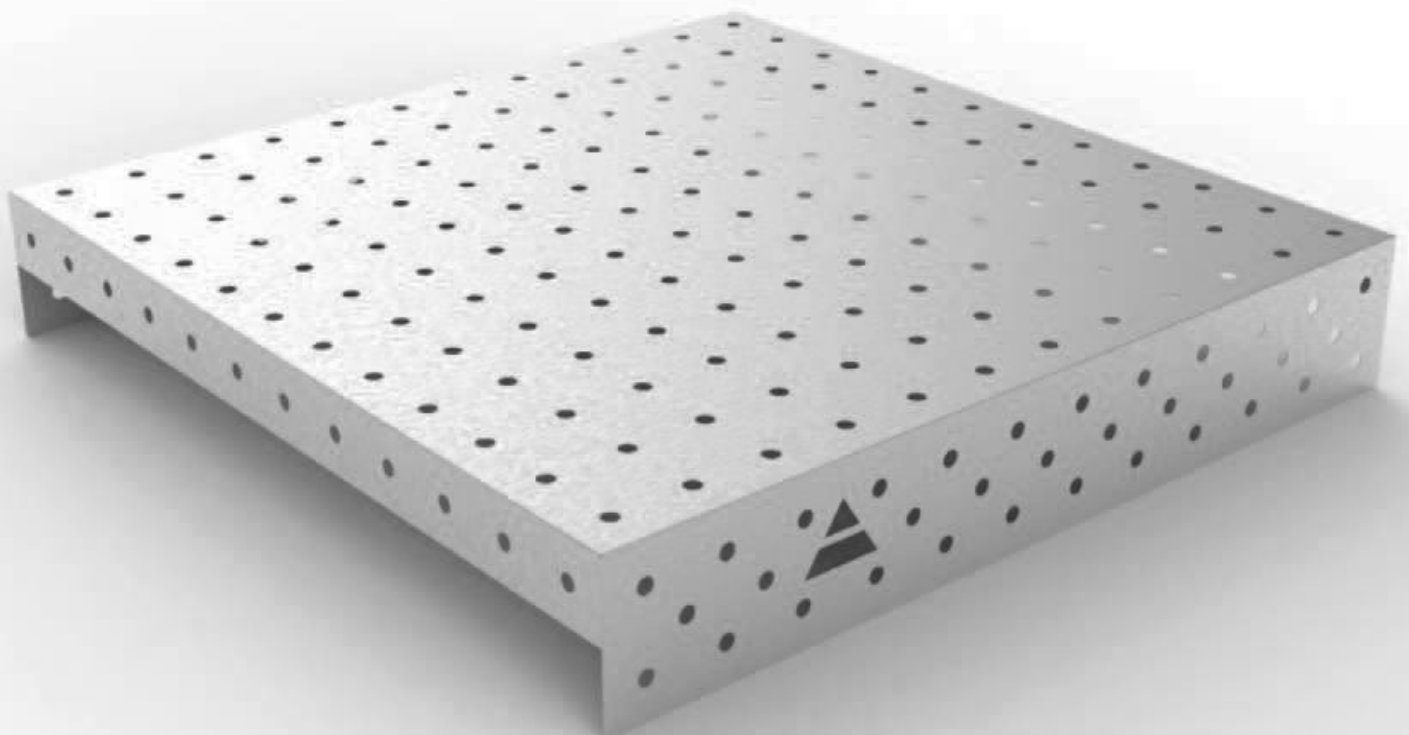

WELDING TABLES - STAINLESS



WELDING TABLES – STAINLESS

INOX series

TECHNICAL PARAMETERS

We also offer traditional GPPH INOX welding tables, which come in a series of tops **PRO** (15 mm) and **PLUS** (12 mm). Each of them in as many as 10 size versions.

INOX SERIES WELDING TABLES ARE CHARACTERIZED BY:

- High electrical conductivity - electrical resistance at 20°C = $0.73 (\Omega \text{ mm}^2)/\text{m}$.
- They are made of stainless steel with a high chromium content, which provides durability and resistance to corrosion.
- When welding stainless steel structures, corrosion foci will not appear on them.
- INOX series of tables is available with legs on feet or on wheels.

Depending on your preferences, you can choose **INOX** welding tables with **PRO** and **PLUS** tops in standard hole systems:

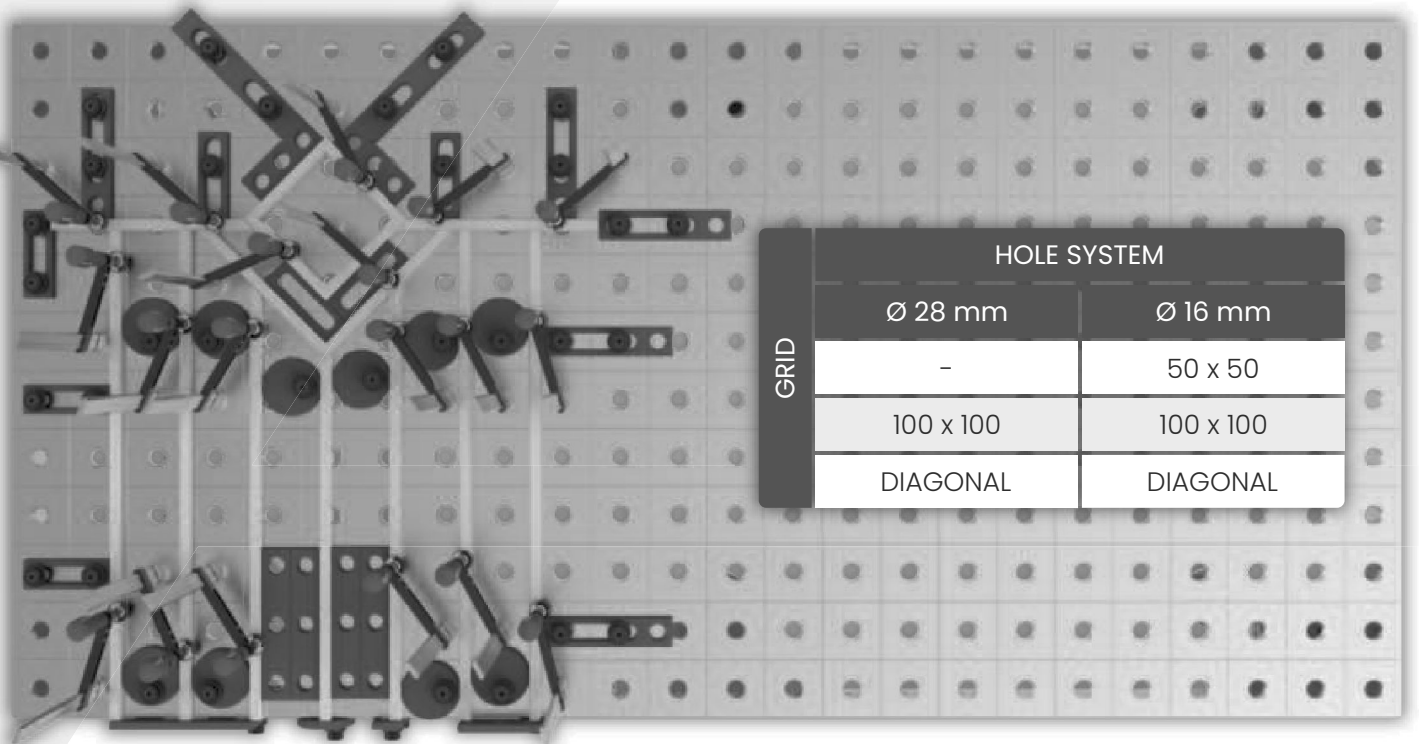

WELDING TABLES – STAINLESS

INOX series

TECHNICAL PARAMETERS

Each table top in the **INOX** version has an engraved scale. In addition, as in traditional welding tables, the tops have **solid and dense ribbing**, which affects the achievement of a **perfectly flat working surface** (flatness tolerance of ± 0.3 mm over the entire dimension of the table top). The ribs are spaced every 400 mm on average. Robust and rigid construction of the tabletop provides **maximum stability during use and protects against deformation**. The height of the side walls of the tables is 200 mm and they are made with a deviation tolerance of $\pm 0.3^\circ$.

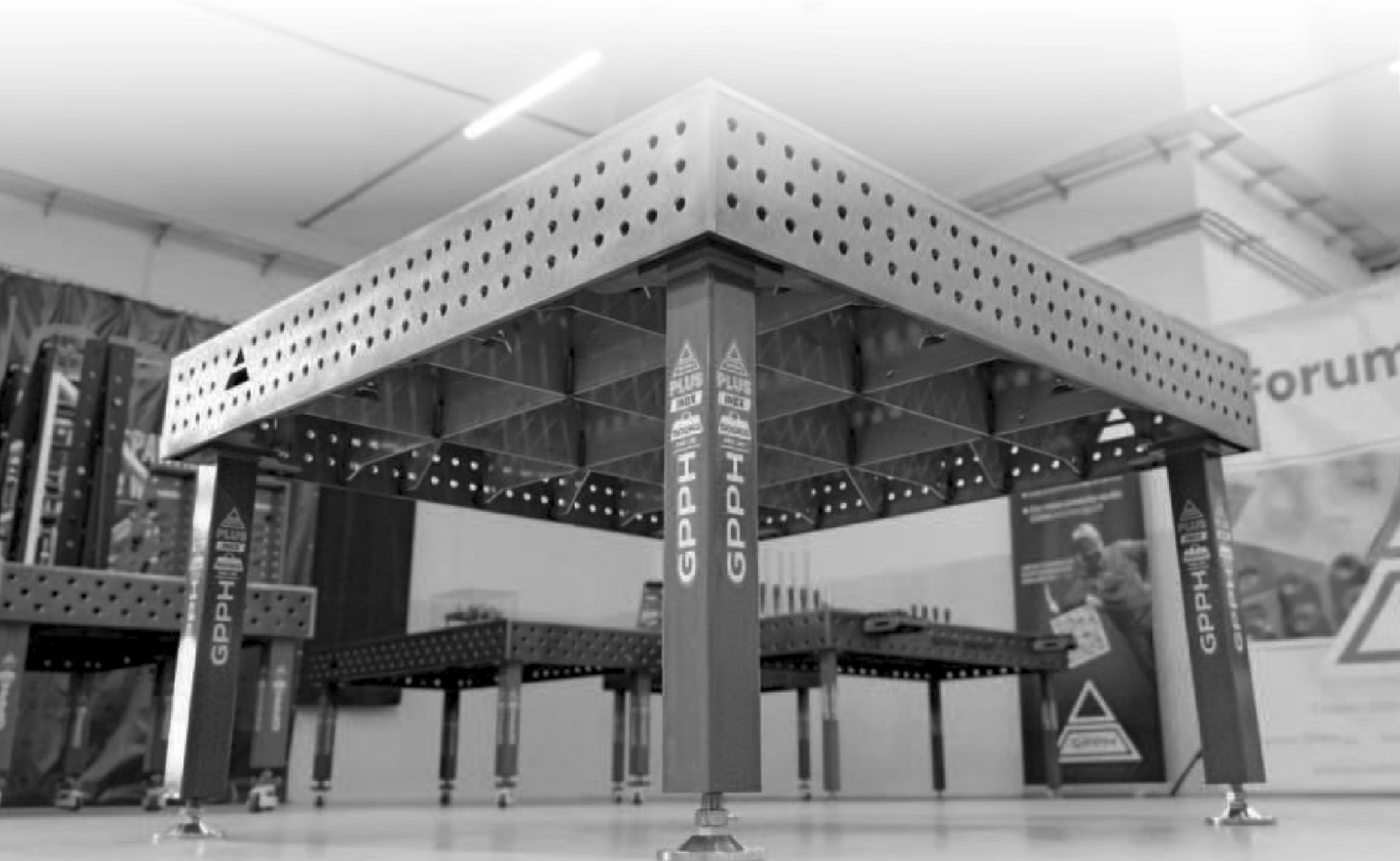

When working on **INOX** series welding tables with **PRO** series tops, you will use milled **PRO** tools, while for **PLUS** series tops you will use **PLUS** series tools. **When working on INOX tables, you can use standard GPPH tools**, as they are powder-coated. Using our tools, you will be able to accurately make any flat and three-dimensional structure in a much shorter time.

You can find the **PRO** series tools on page 114 and the **PLUS** series tools on page 116.

*Comparison of the **PRO** and **PLUS** series of countertops can be found on page 10.



CHEM

For cleaning and protecting INOX series Welding Tables, our **GPPH Chem - PROTECTOR and HD CLEANER**

(you can find more about them on page 143).

WELDING TABLES - STAINLESS

INOX series

TECHNICAL PARAMETERS

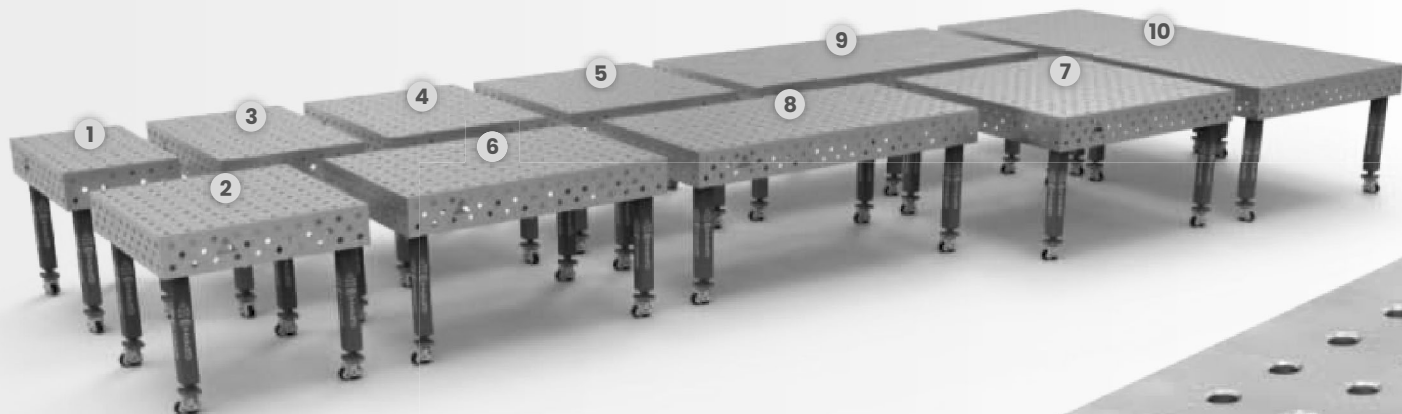

DIMENSIONS OF **PRO** AND **PLUS INOX** TABLES [mm].

1	1000 x 600	6	1500 x 1000
2	1000 x 1000	7	1500 x 1480
3	1200 x 800	8	2000 x 1000
4	1200 x 1000	9	2400 x 1200
5	1200 x 1200	10	3000 x 1480*

*The 3000x1480 GPPH welding table consists of two interconnected 1500x1480 GPPH welding tables.

LOAD CAPACITY AND LEG DIMENSIONS IN EACH SERIES:

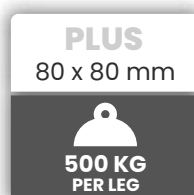
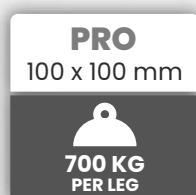



WELDING TABLES – STAINLESS

INOX series – tables with legs on feet



DIMENSIONS AND PRICE LIST



Price list for INOX tables with legs on feet with a system of holes Ø 28 mm and Ø 16 mm in the grid 100x100 mm:

DIMENSIONS [mm]	 	
	PRO INOX	PLUS INOX
1000 x 600		
1000 x 1000		
1200 x 800		
1200 x 1000		
1200 x 1200		
1500 x 1000		
1500 x 1480		
2000 x 1000		
2400 x 1200		
3000 x 1480		

Pricelist for INOX tables with legs on feet with Ø 28 mm and Ø 16 mm hole system in diagonal grid and for tables with Ø 16 mm hole system in 50x50 mm grid:

DIMENSIONS [mm]	  	
	PRO INOX	PLUS INOX
1000 x 600		
1000 x 1000		
1200 x 800		
1200 x 1000		
1200 x 1200		
1500 x 1000		
1500 x 1480		
2000 x 1000		
2400 x 1200		
3000 x 1480		



WELDING TABLES - STAINLESS

INOX series - tables with legs on wheels



DIMENSIONS AND PRICE LIST

Price list for INOX tables with legs on wheels with a system of holes \varnothing 28 mm and \varnothing 16 mm in the grid 100x100 mm:



DIMENSIONS [mm]	 	
	PRO INOX	PLUS INOX
1000 x 600		
1000 x 1000		
1200 x 800		
1200 x 1000		
1200 x 1200		
1500 x 1000		
1500 x 1480		
2000 x 1000		
2400 x 1200		
3000 x 1480		

Price list for INOX tables with legs on wheels with \varnothing 28 mm and \varnothing 16 mm hole system in diagonal grid and for tables with \varnothing 16 mm hole system in 50x50 mm grid:

DIMENSIONS [mm]	  	
	PRO INOX	PLUS INOX
1000 x 600		
1000 x 1000		
1200 x 800		
1200 x 1000		
1200 x 1200		
1500 x 1000		
1500 x 1480		
2000 x 1000		
2400 x 1200		
3000 x 1480		

WELDING TABLES

traditional and stainless

WEIGHTS

DIMENSIONS [mm]	WEIGHT EXPERT	WEIGHT PRO	WEIGHT PRO INOX	WEIGHT PLUS	WEIGHT PLUS INOX	WEIGHT ECO
1000 x 600	370 kg	210 kg	210 kg	170 kg	170 kg	110 kg
1000 x 1000	480 kg	280 kg	290 kg	230 kg	230 kg	150 kg
1200 x 800	460 kg	270 kg	280 kg	220 kg	220 kg	140 kg
1200 x 1000	530 kg	320 kg	320 kg	260 kg	260 kg	170 kg
1200 x 1200	590 kg	350 kg	360 kg	280 kg	290 kg	190 kg
1500 x 1000	620 kg	370 kg	380 kg	300 kg	310 kg	200 kg
1500 x 1480	800 kg	490 kg	510 kg	390 kg	410 kg	270 kg
2000 x 1000	750 kg	460 kg	480 kg	370 kg	380 kg	250 kg
2400 x 1200	990 kg	630 kg	660 kg	510 kg	530 kg	340 kg
3000 x 1480	1480 kg	980 kg	1020 kg	780 kg	810 kg	530 kg

*Weights given as approximate.



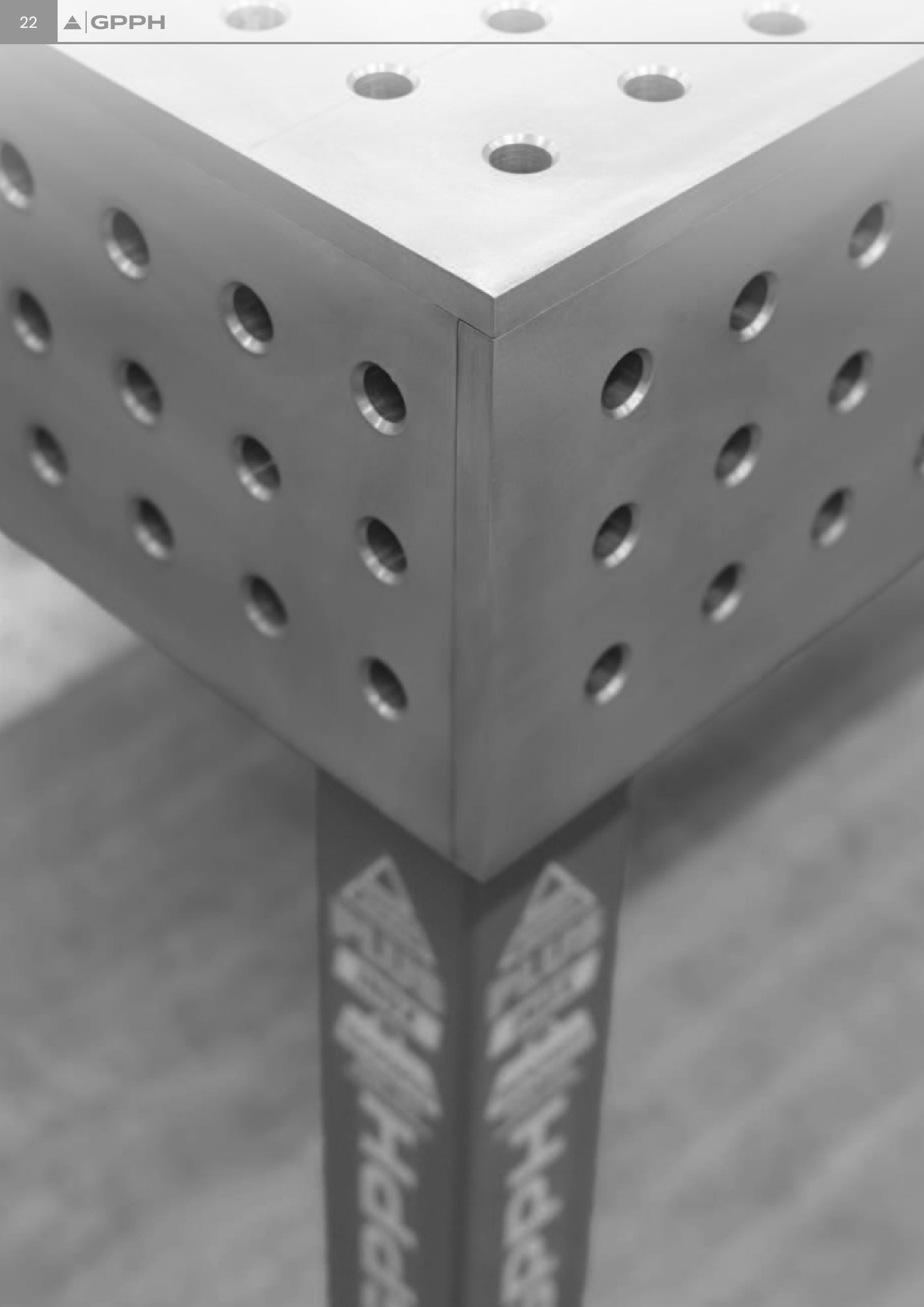

WELDING TABLES - ECONOMIC VERSION

GPPH SMART



MAX
1200 KG
GPPH
12
MM
SMART

WELDING TABLES – ECONOMIC VERSION

SMART series

TECHNICAL PARAMETERS

The new GPPH SMART line of welding tables is an economical alternative that combines functionality with an attractive price. Created for users who need essential welding tools, but do not require advanced features of professional equipment. Ideal for those who appreciate reliability and affordability.

GPPH SMART welding tables is a line of economical welding tables, which comes in two series:

- with **15 mm** thick tops (**SMART 15**)
- with **12 mm** thick tops (**SMART 12**)



All tables come in the version with legs on feet or on wheels.



Depending on your preference, you can choose **GPPH SMART 15** or **GPPH SMART 12** welding tables with \varnothing 16 mm or \varnothing 28 mm hole system in 100x100 grid.

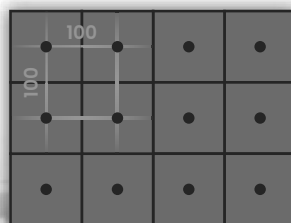

\varnothing 16 100x100

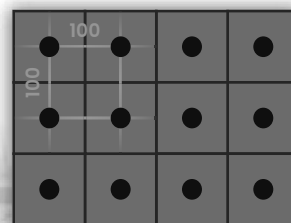

\varnothing 28 100x100



AVAILABLE WELDING TABLE DIMENSIONS GPPH SMART 15 and GPPH SMART 12

1500 x 1000

1500 x 1480

2000 x 1000

2400 x 1200

3000 x 1480*

*The 3000x1480 GPPH welding table consists of two interconnected 1500x1480 GPPH welding tables.





WELDING TABLES – ECONOMIC VERSION

SMART series

DIMENSIONS AND PRICE LIST





Price list for tables with legs on wheels with Ø 28 mm and Ø 16 mm hole system in 100x100 mm grid:



   		
DIMENSIONS [mm]	GPPH SMART 15	GPPH SMART 12
1500 x 1000		
1500 x 1480		
2000 x 1000		
2400 x 1200		
3000 x 1480*		

Price list for tables with legs on wheels with Ø 28 mm and Ø 16 mm hole system in 100x100 mm grid:



   		
DIMENSIONS [mm]	NET PRICE GPPH SMART 15	NET PRICE GPPH SMART 12
1500 x 1000	1 750 EUR	1 290 EUR
1500 x 1480	2 010 EUR	1 430 EUR
2000 x 1000	1 890 EUR	1 390 EUR
2400 x 1200	2 340 EUR	1 660 EUR
3000 x 1480*	4 020 EUR	2 860 EUR



*The 3000x1480 GPPH welding table consists of two interconnected 1500x1480 GPPH welding tables.

WELDING TABLES – ECONOMIC VERSION

SMART series

WEIGHTS

DIMENSIONS [mm]	WEIGHT	
	GPPH SMART 15	GPPH SMART 12
1500 x 1000	310 kg	260 kg
1500 x 1480	420 kg	350 kg
2000 x 1000	390 kg	330 kg
2400 x 1200	520 kg	430 kg
3000 x 1480*	840 kg	700 kg

*Weights given as approximate.

*The 3000x1480 GPPH welding table consists of two interconnected 1500x1480 GPPH welding tables.



WELDING TABLES – ECONOMIC VERSION

SMART series

COMPARISON OF SMART SERIES TO TRADITIONAL GPPH WELDING TABLES

SERIES OF TRADITIONAL WELDING TABLES GPPH PRO	SERIES OF ECONOMIC WELDING TABLES GPPH SMART 15
Flatness tolerance: ± 0.3 mm over the entire top*	Flatness tolerance: ± 0.5 mm over the entire top*
3 rows of holes in the side wall	2 rows of holes in the side wall
Tolerance of hole execution: +0.05mm	
Milled and chamfered holes	
Chamfered holes on the underside	
Milled edges of the tabletop	
Leg profile: 100x100x4 mm	Leg profile: 60x60x4 mm
Load capacity: 700kg / leg (max. load capacity for table with 4 legs: 2800kg)	Load capacity: max. 1800 kg
Number of size versions: 10	Number of size versions: 5
Side wall deflection tolerance: $\pm 0,3^\circ$	Side wall deflection tolerance: $\pm 0,35^\circ$
Available hole grids: 100x100mm, 50x50mm, diagonal	Available hole grids: 100x100mm

SERIES OF TRADITIONAL WELDING TABLES GPPH PLUS	SERIES OF ECONOMIC WELDING TABLES GPPH SMART 12
Flatness tolerance: ± 0.3 mm over the entire top*	Flatness tolerance: ± 0.5 mm over the entire top*
3 rows of holes in the side wall	2 rows of holes in the side wall
Tolerance of hole execution: +0.05mm	
Milled and chamfered holes	
Chamfered holes on the underside	
Milled edges of the tabletop	
Leg profile: 80x80x4 mm	Leg profile: 60x60x4 mm
Load capacity: 500kg / leg (max load capacity for table with 4 legs: 2000kg)	Load capacity: max. 1200 kg
Number of size versions: 10	Number of size versions: 5
Side wall deflection tolerance: $\pm 0,3^\circ$	Side wall deflection tolerance: $\pm 0,35^\circ$
Available hole grids: 100x100mm, 50x50mm, diagonal	Dostępne siatki otworów: 100x100mm

*Provided the table is properly leveled.

WELDING TABLES – ECONOMIC VERSION

SMART series

COMPARISON OF SMART SERIES TO TRADITIONAL GPPH WELDING TABLES

Comparison of the ribbing of the economical GPPH SMART welding tables with the traditional GPPH professional welding tables.

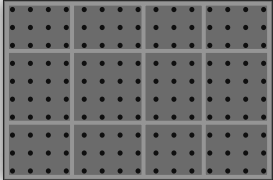
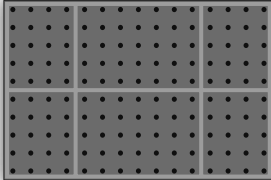
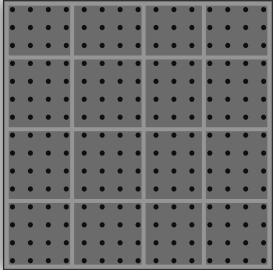
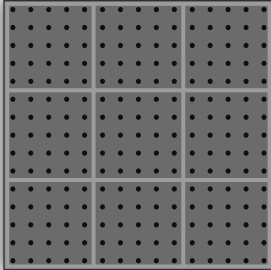
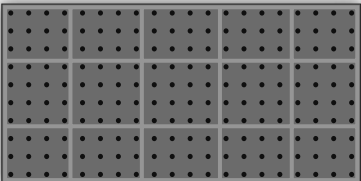
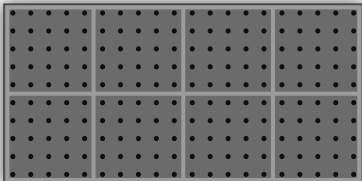
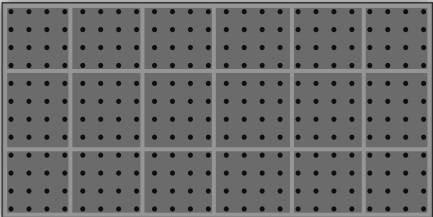
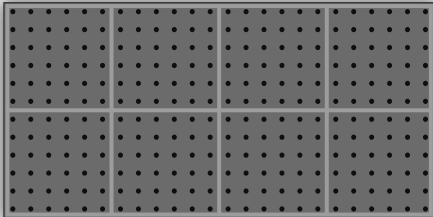
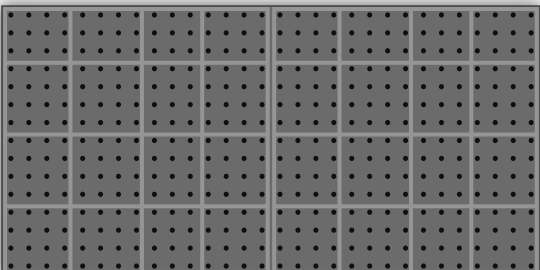
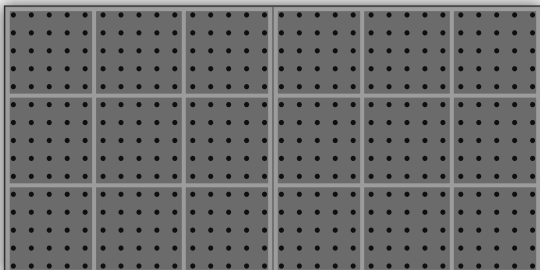
PROFESSIONAL TABLES GPPH	ECONOMIC VERSION GPPH SMART
1500 x 1000	
	
1500 x 1480	
	
2000 x 1000	
	
2400 x 1200	
	
3000 x 1480	
	

WELDING TABLES – ECONOMIC VERSION

SMART series

COMPARISON OF SMART SERIES TO TRADITIONAL GPPH WELDING TABLES

Comparison of economical GPPH SMART tables with traditional GPPH professional welding tables:



WELDING TABLES – ECONOMIC VERSION

SMART series

TOOLKITS

For **SMART** Series welding tables, we offer the **Toolkit S** and **Toolkit XS**, which you will find on pages 136 and 137. These are **ideal starter kits** that allow you to quickly and conveniently get started on your welding table, providing you with the basic tools you need to accurately clamp parts.

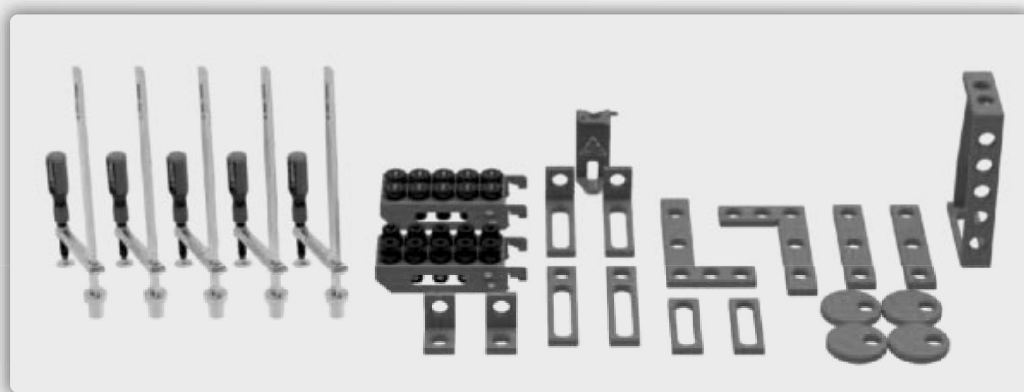

TOOLKIT

S



TOOLKIT

XS

In our offer on page 133 you will also find a **full range of tool sets**, including sets, consisting of up to **250 elements**. Thanks to them you can comprehensively equip your workstation, which will significantly increase the efficiency and convenience of welding.

Buying a ready-made set saves time and **guarantees the compatibility of all elements**, which eliminates the need to select tools on your own. Choosing proven sets, you can be sure that each part will fit perfectly on the table, allowing **precise and comfortable work from day one**.

WELDING TABLES - MODULAR



WELDING TABLES – MODULAR

MWT series

TECHNICAL PARAMETERS

GPPH MODULAR WELDING TABLES
ARE AVAILABLE IN TWO VARIANTS OF TOP PLATES:

material
S355J2+N

tool steel subjected to
The following treatment processes:
nitriding + oxidation



The top of the modular tables consists of milled sliding plates with a thickness of 15 mm, and by adjusting their surface you will get **perfect flatness**. They are made with a system of $\varnothing 28$ mm holes in a 100x100 mm grid.

In addition, the design of our modular tables allows you to increase the number of places of attachment of tools in the gaps between the plates of the tabletop - increased ergonomics of work.

• MODULAR TABLES:

- have milled and chamfered holes for easy tool installation.
- The modular tables are compatible with PRO series tools.
- have wheels with a foot in the base legs with a load capacity of 250 kg per leg.
- the height of the tables can be adjusted from 850 mm - 1150 mm, P=50 mm.
- it is possible to combine the tables to obtain a larger working area.
- optional possibility to purchase side plates.

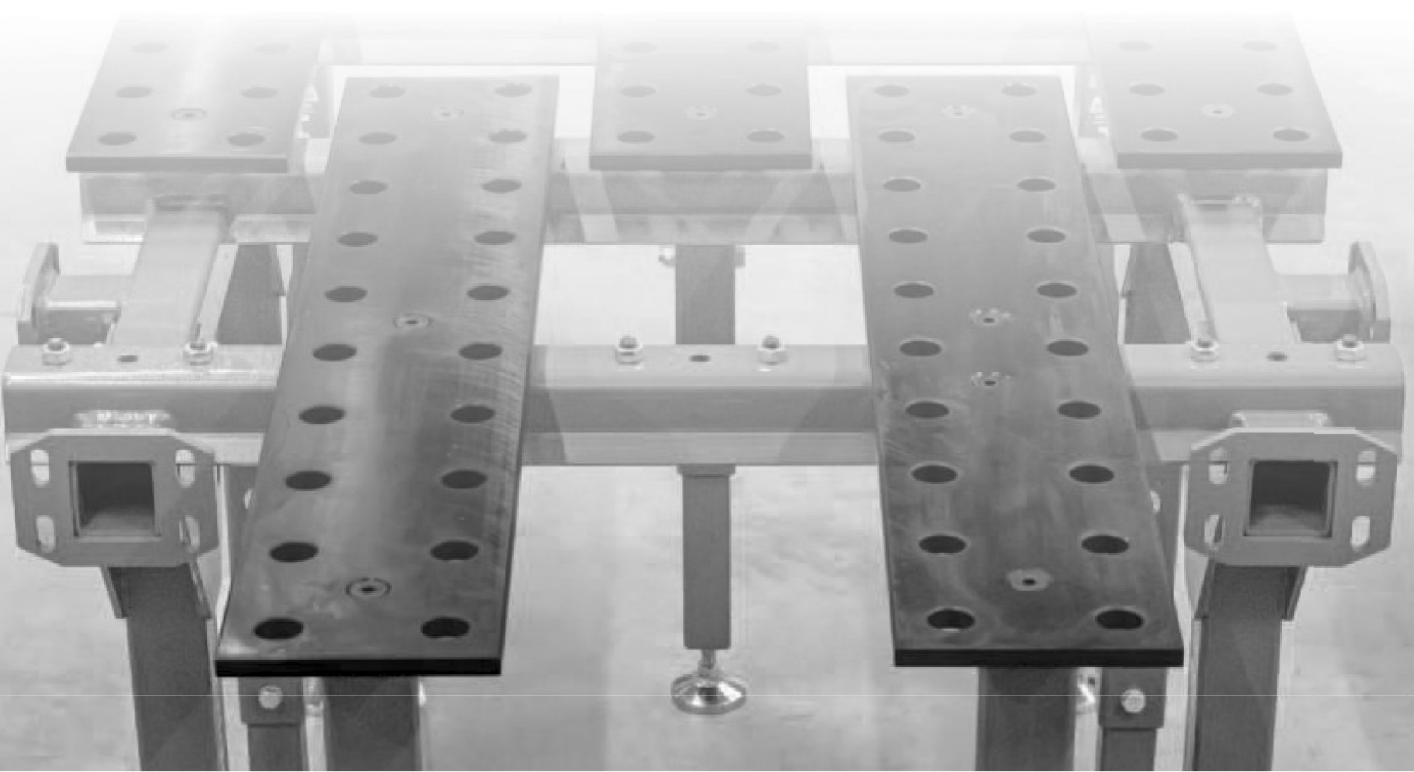

WELDING TABLES – MODULAR



MWT series

TECHNICAL PARAMETERS

TYPES OF MODULAR WELDING TABLES GPPH AND AVAILABLE DIMENSIONS [mm]:

SINGLE TABLES		
1000 x 1000	1200 x 1200	1600 x 1500
		

Single tables are ideal for small-volume production or serve as a base for unlimited expansion of the welding station area.

SINGLE FOLDING TABLES		
1770 x 1000	2170 x 1200	2670 x 1600
		

Each of the single table in our offer can be unfolded thanks to sliding panels and the use of additional legs.

WELDING TABLES – MODULAR

MWT series

TECHNICAL PARAMETERS

TYPES OF MODULAR WELDING TABLES GPPH AND AVAILABLE DIMENSIONS [mm]:

DOUBLE TABLES		
2000 x 1000	2400 x 1200	3200 x 1500
		
<p>The most popular sets are tandems consisting of two single tables. The design of the tables allows expansion in any direction.</p>		

LARGE AREA SETS		
2630 x 1770	3030 x 2170	4000 x 2670
		
<p>Sets are two unfolded modular tables connected to each other with connectors. It is an ideal solution for spatial structures.</p>		

*All tables in the visuals have top plates made of S355J2+N steel.

WELDING TABLES – MODULAR

MWT series

DIMENSIONS AND PRICE LIST

DIMENSIONS [mm]	material S355J2+N	tool steel subjected to nitrided and oxidized
-----------------	-------------------	---

SINGLE TABLES

1200 x 1000

1200 x 1200

1600 x 1500

SINGLE FOLDING TABLES

1770 x 1000

2170 x 1200

2670 x 1600

DOUBLE TABLES

2630 x 1770

3030 x 2170

4000 x 2670

LARGE AREA SETS

1200 x 1200

1200 x 1200

1200 x 1200

SET OF SIDE PLATES

for a single modular table with dimension 1000x1000

for single modular table with dimension 1200x1200

for single modular table with dimension 1600x1500



WELDING TABLES - WELDING & ASSEMBLY TABLES



WELDING TABLES – WELDING & ASSEMBLY TABLES

BASIC series

TECHNICAL PARAMETERS

Where will you use the **BASIC** welding table? Anywhere where precision is necessary during welding.

It does not matter whether you do your welding work in a classic manual way or use welding robots for it – **BASIC** tables are the perfect choice! Your constructions will finally be made accurately, without unnecessary corrections.

If you use a welding robot for your work, we have a great solution for you. **BASIC** welding table is perfect as a **base for robotic welding**, as well as measuring stations. For such work, side walls are not used, so **BASIC** welding table meets all your needs, and at the same time it is **more affordable** compared to traditional welding tables with side walls.

BASIC TABLES:

- perfectly flat working surface [± 0.3 mm on the whole tabletop].
- massive and rigid table top substructure with a height of 80mm.
- chamfered and milled holes for easy installation of tools, made to a tolerance of $+0.05$ mm.
- engraved scale in 100x100 mm grid.
- made of material S355J2+N in accordance with ISO 2768-1.
- height adjustment with standard legs about 880–930 mm.
- all tables are reinforced with ribs, spaced every 400 mm on average.
- milled edges of the top.
- thickness of the top 12 mm.
- legs made of 60x60 mm profile.
- load capacity of the table up to 1 500 kg (250kg/leg).

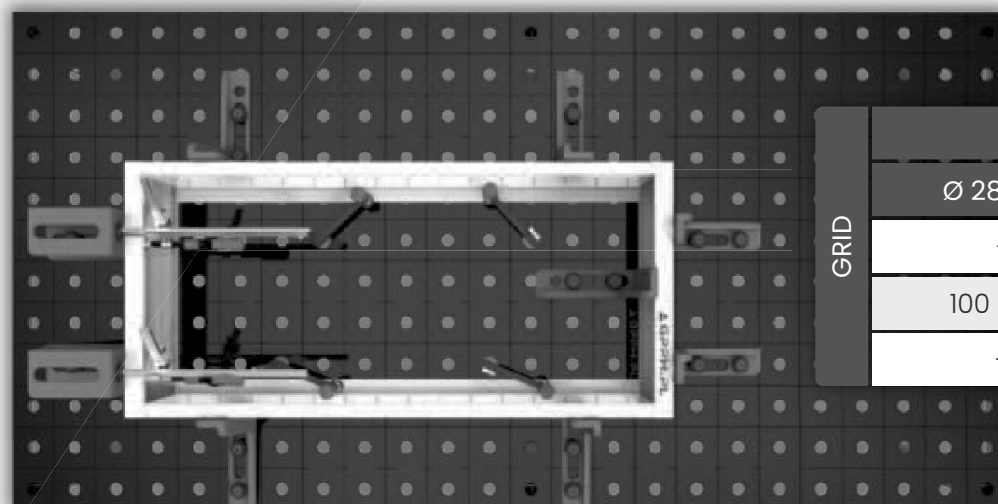

GRID	HOLE SYSTEM	
	Ø 28 mm	Ø 16 mm
-	-	50 x 50
100 x 100	100 x 100	100 x 100
-	-	DIAGONAL

WELDING TABLES – WELDING & ASSEMBLY TABLES

BASIC series

TECHNICAL PARAMETERS

BASIC SERIES TABLE DIMENSIONS:



BASIC TABLE DIMENSIONS [mm].			
1	1000 x 600	6	1500 x 1000
2	1000 x 1000	7	1500 x 1480
3	1200 x 800	8	2000 x 1000
4	1200 x 1000	9	2400 x 1200
5	1200 x 1200		

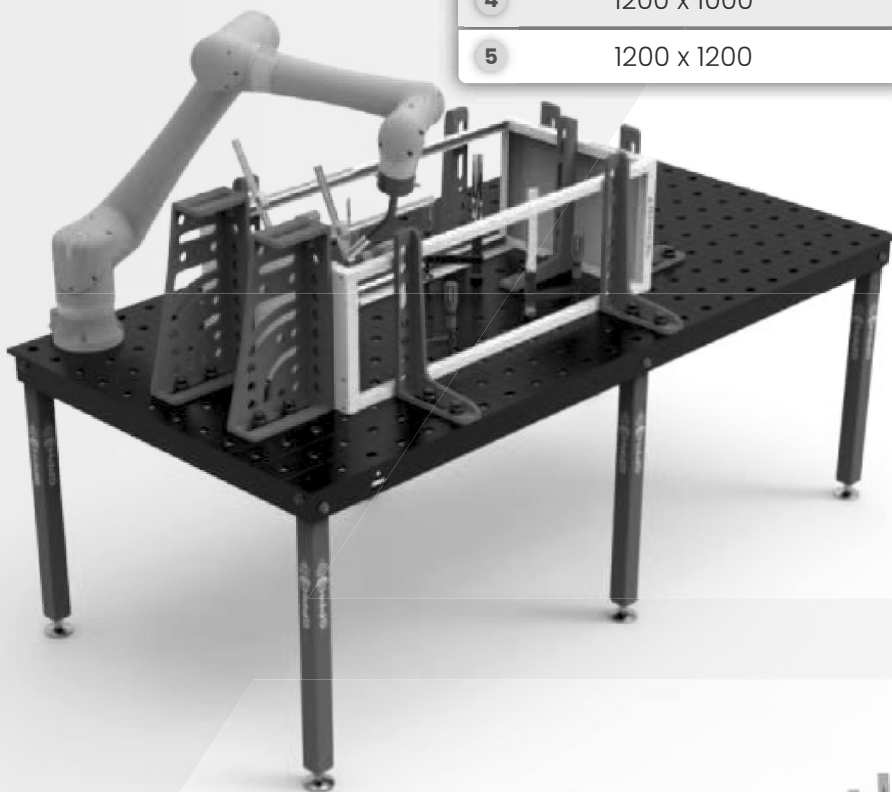

DIMENSIONS [mm]	WEIGHT*
1000 x 600	110 kg
1000 x 1000	160 kg
1200 x 800	150 kg
1200 x 1000	180 kg
1200 x 1200	200 kg
1500 x 1000	220 kg
1500 x 1480	300 kg
2000 x 1000	280 kg
2400 x 1200	390 kg

*These are approximate values.

Using the **PLUS** series of milled tools, you will build a suitable and easy-to-use work environment for making repetitive flat as well as spatial structures.



WELDING TABLES – WELDING & ASSEMBLY TABLES



BASIC series – tables with legs on feet

DIMENSIONS AND PRICE LIST

GPPH welding table legs are available with feet and wheels. The foot provides reliable support, keeping the table top level and stable, allowing you to concentrate on making precise welds and assemblies. Thus, tables with feet provide a solid and reliable base for professional welders and tinkerers.

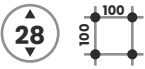
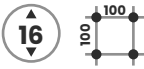

 	
DIMENSIONS [mm]	
1000 x 600	
1000 x 1000	
1200 x 800	
1200 x 1000	
1200 x 1200	
1500 x 1000	
1500 x 1480	
2000 x 1000	
2400 x 1200	

  	
DIMENSIONS [mm]	
1000 x 600	
1000 x 1000	
1200 x 800	
1200 x 1000	
1200 x 1200	
1500 x 1000	
1500 x 1480	
2000 x 1000	
2400 x 1200	



WELDING TABLES – WELDING & ASSEMBLY TABLES



BASIC series – tables with legs on wheels

DIMENSIONS AND PRICE LIST

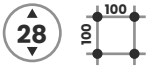
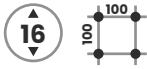

Welding tables with legs on wheels, are an excellent option for those who need mobility and flexibility in organizing their workspace. Wheels allow the table to be easily moved around the workshop, which increases work efficiency. In addition, the wheels are equipped with a locking mechanism that keeps the table in a stable position during welding or assembly.

 	
DIMENSIONS [mm]	
1000 x 600	
1000 x 1000	
1200 x 800	
1200 x 1000	
1200 x 1200	
1500 x 1000	
1500 x 1480	
2000 x 1000	
2400 x 1200	

 	
DIMENSIONS [mm]	
1000 x 600	
1000 x 1000	
1200 x 800	
1200 x 1000	
1200 x 1200	
1500 x 1000	
1500 x 1480	
2000 x 1000	
2400 x 1200	



WELDING TABLES – WELDING & ASSEMBLY TABLES

DIY series

TECHNICAL PARAMETERS AND PRICE LIST

The **DIY welding and assembly table** is 1200x800 mm and comes with $\varnothing 16$ mm holes in a 50x50 mm grid. The holes have a manufacturing tolerance of ± 0.1 mm. The tabletop has an engraved graduation in a 100x100 mm grid. The height of the table is 880 mm. The **DIY welding and assembly table** is made of S355J2+N material.

DIY tables are **densely ribbed**, which contributes to their perfect flatness [± 0.5 mm across the table top]. They are equipped with pendulum feet to level out floor irregularities.

The **DIY** table top is 8 mm thick. The maximum load capacity of the table is 500 kg, while its weight is about 90 kg. This product will be ideal not only for a welder, but also **for a tinker, carpenter, auto mechanic, as an auxiliary table for CNC machines, as well as for various workshops.**

Compatible with the **DIY** tables are **PLUS** series tools attached with the **ECO/PLUS** adjustable mandrel (check out the tools on page 116).

Engraved scale in grid
100x100 mm and mounting holes
in system I6, in 50x50 grid

Work table with a thickness of
8 mm made of steel S355J2+N

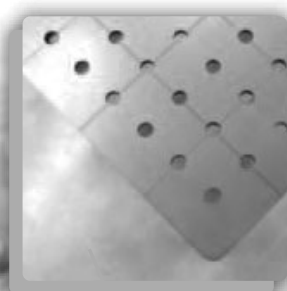

DIY TABLE

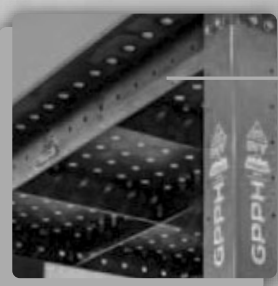

Metal rigid frame
reinforced with ribs



Legs equipped with swing feet
to compensate for floor irregularities

WELDING TABLES – WELDING & ASSEMBLY TABLES

DIY series

ACCESSORIES AND TOOL KITS – PRICE LIST

Adapters for tool shelves are an indispensable accessory, if you want to mount a tool shelf on a **DIY** series welding table . Since these tables don't have side walls, standard shelf mounting isn't possible - so we've created special adapters that provide a stable and secure attachment.

With adapters you can easily **organize your workspace**, keeping tools and accessories within easy reach. This practical solution allows you to maximize the use of workspace and increase the comfort of your work, without affecting the functionality of the table.



ADAPTER FOR TOOL SHELVES



SET OF WHEELS FOR THE TABLE

For **DIY** series welding tables, we recommend the **XS Toolkit** and the **2XS Toolkit**, which you can find on our page 137. These are an excellent choice for those starting out on a welding table - they provide key tools for efficient fixturing of parts and make the first stages of work easier.

With tool sets purchased for **DIY** tables, tool shelf adapters are additionally included.



TOOLKIT

XS



TOOLKIT

2XS

Deciding on a ready-made set, you gain the **certainty that all elements are perfectly matched**, which eliminates the need to select them separately. This is not only convenience, but also efficiency - well-chosen tools allow for **faster, more precise and comfortable work**.



GPPH
DIY
500KG
MAX

GPPH

WELDING TABLES - OCTAGONAL



WELDING TABLES – OCTAGONAL

OCT series

TECHNICAL PARAMETERS

INNOVATIVE SOLUTION FOR INDUSTRY

Octagonal welding tables, dedicated for robotization, are an innovative solution for industries that rely on automation of welding processes. They are characterized by a unique octagon shape, which works perfectly with robotic welding systems.

OCT series tables are widely used in manufacturing, especially where there is a need for automation and precision in welding processes. They are ideal for the automotive, aerospace and steel structure manufacturing industries.

PRECISION AT THE HIGHEST LEVEL: The octagonal shape of the table allows precise positioning of parts, which is crucial in applications where every millimeter matters.

FLEXIBILITY FOR DIFFERENT APPLICATIONS: Octagonal tables are suitable for use with various welding robots.

STABILITY AND DURABILITY: The design of GPPH tables is based on high-quality materials, which guarantees the stability and durability of the tables even under intensive use.

AUTOMATION INTEGRATION: The tables have special mounting points and holes to facilitate integration with automation systems, which greatly speeds up the implementation of production lines.

WORKSPACE OPTIMIZATION: The octagonal shape allows for optimal use of working space, which is extremely important for production facilities where every square meter matters.

OCT TABLE DIMENSIONS:

600 x 600

800 x 800

1000 x 1000

1200 x 1200

1400 x 1400



TECHNICAL PARAMETERS OF OCT TABLETOP:

Table flatness tolerance	±0,3 mm
Tolerance of the execution of the holes	±0,05 mm
Chamfered / milled holes	✓
Chamfered holes on the underside	✓
3 rows of holes in the side wall	✓

WELDING TABLES – OCTAGONAL

OCT series

PRICE LIST

DIMENSIONS [mm]	28		16	
	PRO	PRO INOX	PLUS	PLUS INOX
600 x 600				
800 x 800				
1000 x 1000				
1200 x 1200				
1400 x 1400				

600 x 600				
800 x 800				
1000 x 1000				
1200 x 1200				
1400 x 1400				

16				

The load capacity of OCT welding tables depends on the type of swivel with which they will work. To precisely determine the load capacity, we encourage you to contact us - just let us know the specifications of the swivel you have, and our specialists will make a detailed analysis and provide an individual solution. In addition, when ordering, it is necessary to specify the dimension of the orifice to which the octagonal table will be attached.

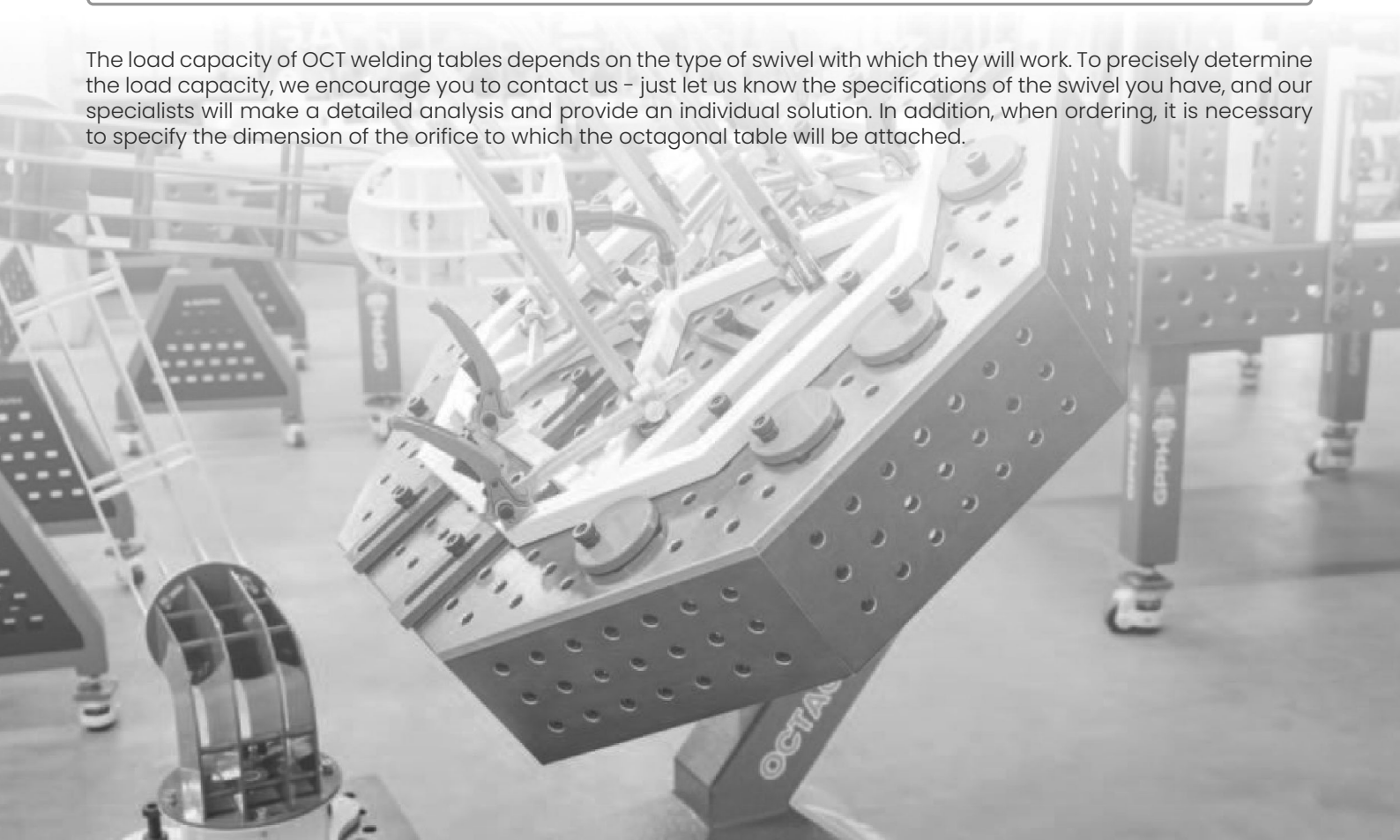

WELDING TABLES - OCTAGONAL

OCT series

TECHNICAL PARAMETERS

DIMENSIONS [mm]	WEIGHT PRO	WEIGHT PRO INOX	WEIGHT PLUS	WEIGHT PLUS INOX
600 x 600	90 kg	90 kg	70 kg	70 kg
800 x 800	140 kg	140 kg	110 kg	110 kg
1000 x 1000	185 kg	185 kg	150 kg	150 kg
1200 x 1200	245 kg	245 kg	195 kg	195 kg
1400 x 1400	310 kg	310 kg	245 kg	245 kg

*These are approximate values.

GRID	HOLE SYSTEM	
	Ø 28 mm	Ø 16 mm
	-	50 x 50
	DIAGONAL	DIAGONAL

TOP VERSIONS AVAILABLE FOR OCT TABLES		
S355J2+N steel	PRO	PLUS
INOX 1.4301 steel	PRO INOX	PLUS INOX

WELDING TABLES - LIFTING

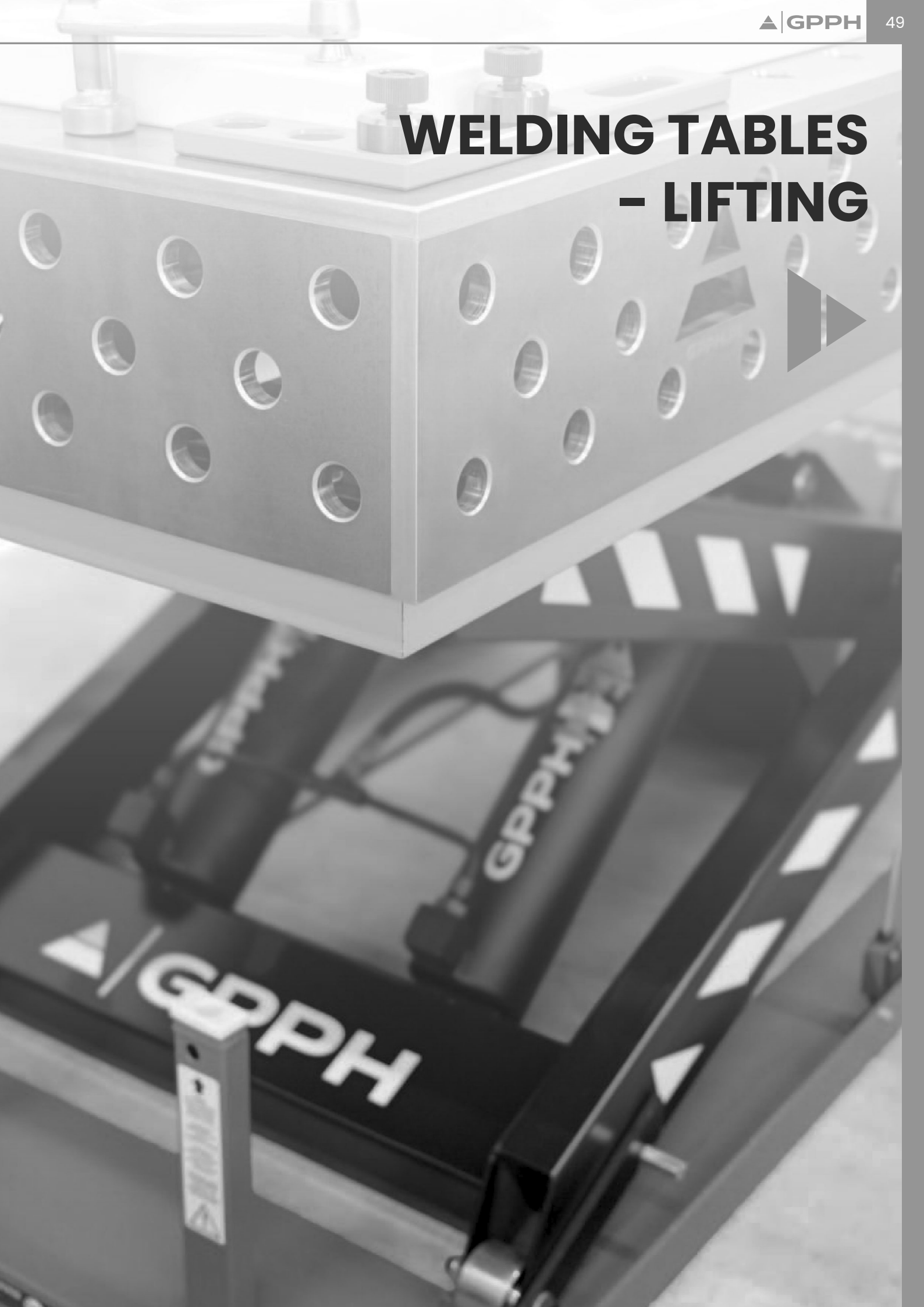

WELDING TABLES – LIFTING

with hydraulic lifting system – **XWT** series

TECHNICAL PARAMETERS

GPPH welding tables with hydraulic lifting system are specialized tables with automatic table topheight adjustment.

WELDING TABLES WITH HYDRAULIC LIFTING SYSTEM LIFTING SYSTEM HAVE:

- Overload valve to prevent lifting too heavy loads.
- Safety valve to stop lowering when hydraulic lines break.
- Limit switches to prevent crushing or injury to the user.

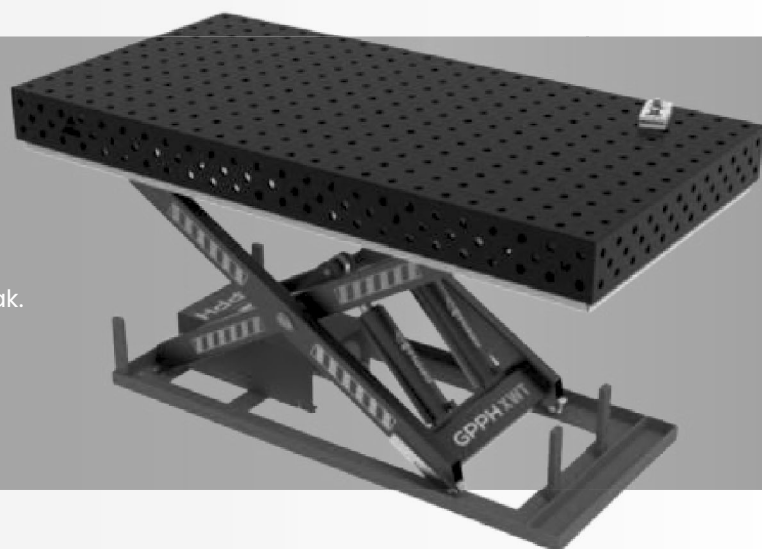

TOP VERSIONS AVAILABLE FOR **XWT** TABLES

S355J2+N steel	EXPERT	PRO	PLUS	ECO
INOX 1.4301 steel	PRO INOX	PLUS INOX		

TABLETOP DIMENSIONS AVAILABLE FOR **XWT** TABLES

1500 x 1000	1500 x 1480	2000 x 1000	2400 x 1200
-------------	-------------	-------------	-------------

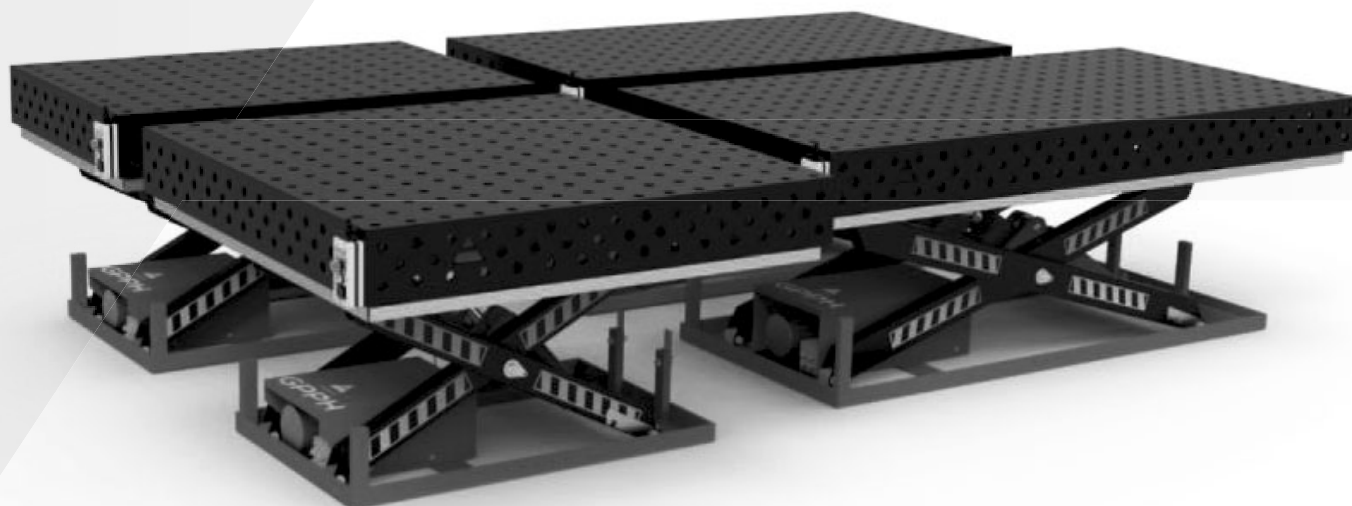

WELDING TABLES – LIFTING

with hydraulic lifting system – XWT series

TECHNICAL PARAMETERS

XWT series are modern welding tables equipped with a **hydraulic lifting system**, which allows you to smoothly adjust the height for maximum comfort. The ability to customize the workstation significantly reduces fatigue and increases the efficiency of welding operations. Thanks to its **robust design and precise workmanship**, **XWT** tables guarantee reliability even in demanding industrial conditions. It is the perfect solution for professionals who expect not only convenience, but also safety and maximum precision in their daily work.

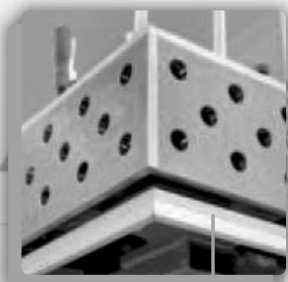

Protective barrier to prevent the risk of injury and crushing



Ergonomic and intuitive control cassette for stepless height adjustment



Safety valve system guaranteeing full protection in case of hose failure



Dedicated support frame to ensure perfect flatness of the tabletop together with polyamide rollers to protect against electrical surges

WELDING TABLES – LIFTING

with hydraulic lifting system – XWT series

TECHNICAL PARAMETERS

TABLETOP DIMENSION [mm]	1500 x 1000	1500 x 1480	2000 x 1000	2400 x 1200
XWT WEIGHT WITH EXPERT TOP [kg]	730	950	1020	1310
XWT WEIGHT WITH PRO TOP [kg]	550	700	790	990
XWT WEIGHT WITH PLUS TOP [kg]	480	610	700	870
XWT WEIGHT WITH ECO TOP [kg]	410	510	610	750

*These are approximate values.

TABLETOP DIMENSION [mm]	1500 x 1000	1500 x 1480	2000 x 1000	2400 x 1200
MAX LOAD CAPACITY PRO PLUS ECO [kg]	1600	1500	3500	3400
MAX LOAD CAPACITY EXPERT [kg]	1400	1200	3200	2900
LIFTING TIME WITH LOAD [s]	20-25	20-25	30-40	30-40
MAX TABLE HEIGHT [mm]	1150	1450	1200	1550
MIN TABLE HEIGHT [mm]	480	480	550	550
DIMENSIONS OF THE LIFT BASE [mm]	1220x785	1220x785	1863x890	1863x890
ENGINE POWER [kW]	2.2	2.2	2.2	2.2

*Because of the massive design of the EXPERT series tops, the load capacity of the XWT table with this top is lower than that of the PRO, PLUS and ECO series.

TECHNICAL PARAMETERS OF THE XWT BASE

supply voltage	400 V
revolutions [rpm]	1400
class of protection	IP54
insulation class	F

HOLE SYSTEM







GRID	Ø 28 mm	Ø 16 mm
	-	50 x 50
	100 x 100	100 x 100
	DIAGONAL	DIAGONAL

WELDING TABLES – LIFTING









with hydraulic lifting system – XWT series

DIMENSIONS AND PRICE LIST

Price list for tables with a top made of steel S355J2+N with a system of holes Ø 28 mm and Ø 16 mm in the grid 100x100 mm:

DIMENSIONS [mm]	 	 	 	
	EXPERT	PRO	PLUS	ECO
1500 x 1000				
1500 x 1480				
2000 x 1000				
2400 x 1200				

Price list for tables with a top made of S355J2+N steel with a system of holes Ø 28 mm and Ø 16 mm in the diagonal grid, and for tables with a system of holes fi 16 mm in the grid 50x50 mm:

DIMENSIONS [mm]	 	 	 	 	
	EXPERT	PRO	PLUS	ECO	
1500 x 1000					
1500 x 1480					
2000 x 1000					
2400 x 1200					







WELDING TABLES – LIFTING







with hydraulic lifting system – XWT series

DIMENSIONS AND PRICE LIST

Price list for tables with a top made of stainless steel grade 1.4301 with a system of holes \varnothing 28 mm and \varnothing 16 mm in a 100x100 mm grid:

DIMENSIONS [mm]	   	
	PRO INOX	PLUS INOX
1500 x 1000		
1500 x 1480		
2000 x 1000		
2400 x 1200		

Price list for tables with a top made of stainless steel in grade 1.4301 with a system of holes \varnothing 28 mm and \varnothing 16 mm in the diagonal grid, and for tables with a system of holes \varnothing 16 mm in the grid 50x50 mm:

DIMENSIONS [mm]	     	
	PRO INOX	PLUS INOX
1500 x 1000		
1500 x 1480		
2000 x 1000		
2400 x 1200		

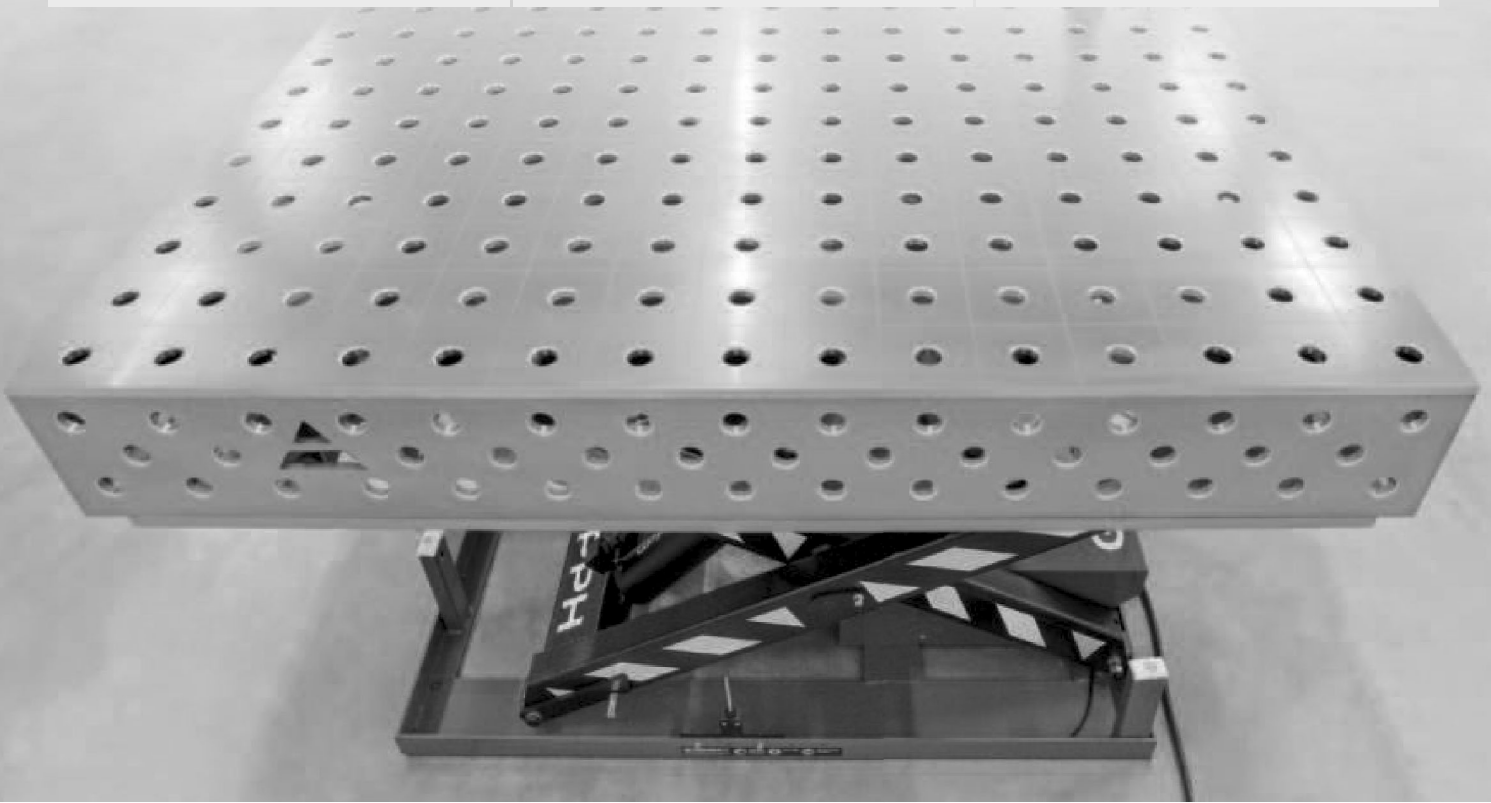

WELDING STATION



WELDING STATION

WELDSTATION series

TECHNICAL PARAMETERS

WELDSTATION is an indispensable welding station that revolutionizes the organization of the welder's workstation. Equipped with an innovative tool storage system, **WELDSTATION** provides convenience, functionality and efficiency during the welding process. **WELDSTATION** was designed for optimal organization of tools necessary for the structural assembly and welding process. The station's enclosure includes drawers, perforated panels for mobile tool shelves, and a generously sized storage area that allows storage and easy access to essential accessories.

ERGONOMIC WELDING TABLE: The centerpiece of the WeldStation is a solid welding table top that provides a stable and comfortable work surface.

DURABLE CONSTRUCTION: WeldStation is made of high quality materials, which guarantees its durability and strength even under intensive use in harsh industrial conditions.

AESTHETIC APPEARANCE: In addition to its functionality, WeldStation also looks elegant and professional. The aesthetic design makes the welding station not only a practical working tool, but also an attractive piece of equipment in any workshop.



WELDING STATION

WELDSTATION series

TECHNICAL PARAMETERS

TABLETOP VERSIONS AVAILABLE FOR WELDING STATIONS

S355J2+N steel	EXPERT	PRO	PLUS	ECO
INOX 1.4301 steel	PRO INOX	PLUS INOX		

DIMENSIONS OF WELDING STATIONS

3000 x 1480	2400 x 1200	2000 x 1000	1500 x 1480
-------------	-------------	-------------	-------------

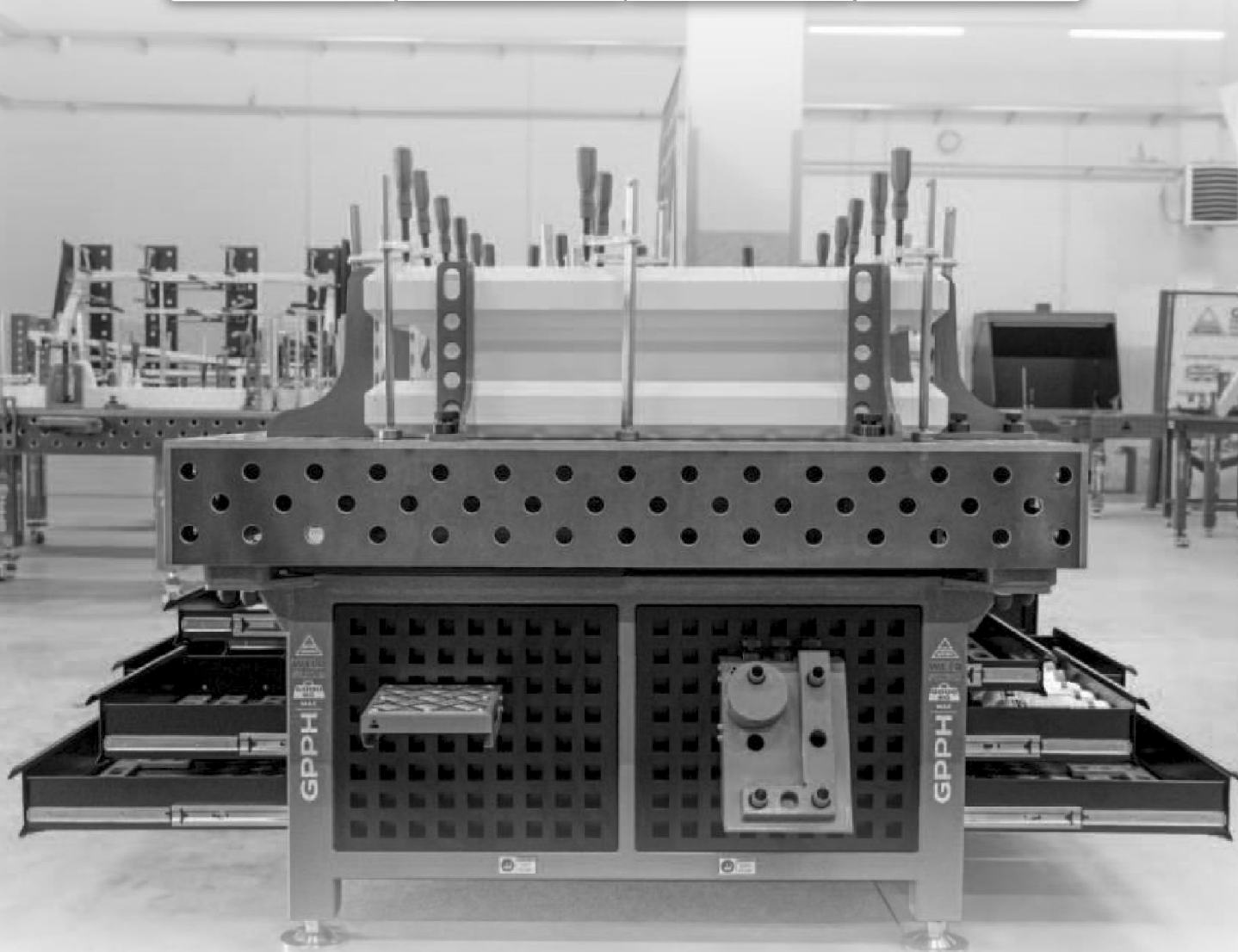

The tool storage system body stiffens the welding table, so the product reaches a load capacity of 4000 kg or 6000 kg (depending on the selected dimensional version). It has special reinforcements dedicated to transporting it with a forklift or "pallet trucks".

We also offer a set of drawers for welding tables - this is a more economical version than WELDSTATION and can be found on page 60.

WELDING STATION

WELDSTATION series

TECHNICAL PARAMETERS AND PRICE LIST

DIMENSIONS [mm]						
	EXPERT	PRO	PRO INOX	PLUS	PLUS INOX	ECO
1500 x 1480						
2000 x 1000						
2400 x 1200						
3000 x 1480						

DIMENSIONS [mm]						
	EXPERT	PRO	PRO INOX	PLUS	PICE PLUS INOX	PRICE ECO
1500 x 1480						
2000 x 1000						
2400 x 1200						
3000 x 1480						

DIMENSIONS [mm]	WEIGHT*
1500 x 1480	280 kg
2000 x 1000	270 kg
2400 x 1200	370 kg
3000 x 1480	525 kg

*These are approximate values and apply to the building itself with drawers, without the welding table tops.

SET OF DRAWERS AND BOTTOM SHELF



SET OF DRAWERS FOR WELDING TABLES

TECHNICAL PARAMETERS

Innovative sets of drawers for welding tables are a modern solution that increases the functionality and ergonomics of the workstation. Mounted under the table top, these drawers provide easy access to all necessary tools, eliminating the need to search for them throughout the workshop. This allows each welder to focus on his work, confident that everything he needs is within easy reach.

ADVANTAGES AND FUNCTIONALITIES:

EASY ACCESS TO TOOLS: With drawers located directly under the table top, all the tools you need are always at hand, making work much faster and eliminating the frustration of searching for equipment.

ORDER AND ORGANIZATION: Thanks to dedicated tool spaces, the workstation always remains neat and tidy, enhancing the welder's comfort and safety.

TIME SAVING: Less time spent looking for tools means more time for productive tasks, which translates into increased efficiency of the entire workshop.

INCREASED SAFETY: The organization of tools in drawers minimizes the risk of trips and accidents, which is crucial for a safe working environment.

Drawer kits are manufactured for every dimension and every series of traditional GPPH welding tables.



SET OF DRAWERS FOR WELDING TABLES

DIMENSIONS AND PRICE LIST

DIMENSIONS [mm]	
1000 x 1000	
1200 x 800	
1200 x 1000	
1200 x 1200	
1500 x 1000	
1500 x 1480	
2000 x 1000	
2400 x 1200	
3000 x 1480	



BOTTOM SHELF FOR WELDING TABLES

TECHNICAL PARAMETERS

Bottom shelf for welding tables is a practical solution for any workshop. Mounted to the legs of the table, this shelf is an ideal place to store welding machines, tools or profiles from which structures will be welded later. Thanks to it, all the necessary elements are always at hand, which makes work much easier and allows you to better organize your workspace.

OPTIMAL STORAGE: The bottom shelf allows you to conveniently place welders, tools and profiles that are needed during the work. This makes all necessary items easily accessible, speeding up the welding process and organization.

SPACE SAVING: It allows efficient use of space under the table, which is especially important in smaller workshops where every centimeter of space counts.

DURABILITY AND STRENGTH: Made of high quality materials, the shelf is characterized by high resistance to mechanical damage and corrosion. The shelving section is made of perforated sheet metal, which ensures stability and safety of stored items.

UNIVERSALITY: The shelves are manufactured for each dimension and each series of GPPH welding tables, allowing easy adaptation to different models and needs.



BOTTOM SHELF FOR WELDING TABLES

TECHNICAL PARAMETERS

BOTTOM SHELVES ARE MANUFACTURED FOR EACH DIMENSION AND EACH SERIES OF GPPH WELDING TABLES.

The bottom shelf is solidly designed to ensure maximum functionality and safety during work. The perforated sheet metal of which the bottom shelf is made guarantees durability and allows even heavier tools and materials to be stored. Thanks to the variety of available sizes, the bottom shelf can be easily mounted to any GPPH series welding table.

IDEAL SOLUTION FOR WELDING WORKSHOPS

The bottom shelf for welding tables is an indispensable piece of equipment for any workshop, which allows you to make optimal use of the available space and better organize your work. Whether you need space for a welder, tools or profiles, the bottom shelf will ensure that everything is within easy reach, ready for use. It is a solution that increases comfort and efficiency, supporting professionals in their daily tasks.

DIMENSIONS [mm]	
1000 x 1000	
1200 x 800	
1200 x 1000	
1200 x 1200	
1500 x 1000	
1500 x 1480	
2000 x 1000	
2400 x 1200	
3000 x 1480	

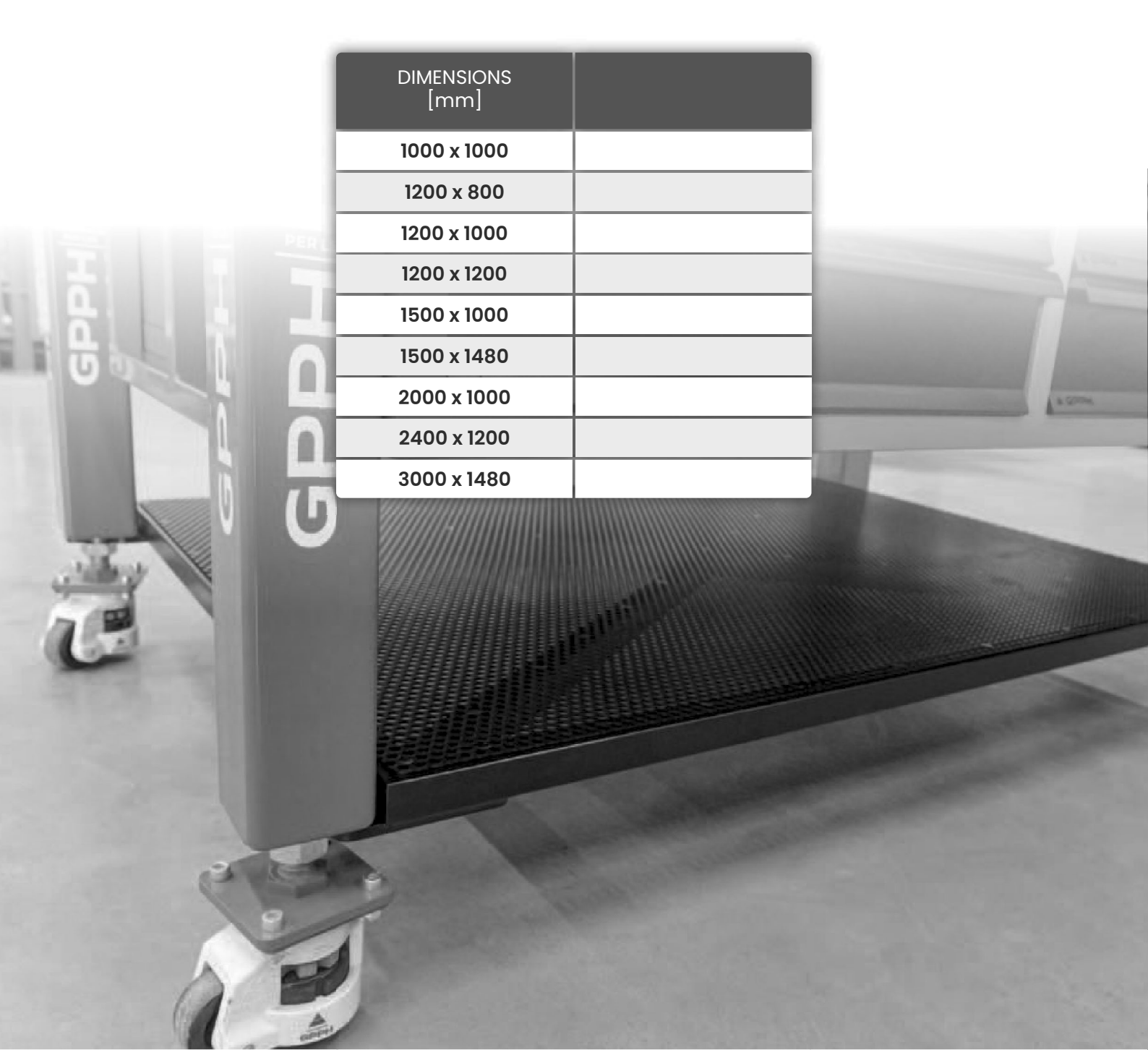



PLUS
INDEX
500KG
500KG PULLEC
GPPH

PLUS
INDEX
500KG
500KG PULLEC
GPPH

GPPH PL

GPPH

GRINDING-WELDING STATION



GRINDING-WELDING STATION

SOG series

TECHNICAL PARAMETERS

The **grinding-welding station** is used for capturing and removing dust and gases generated during grinding with a manual grinder or welding-welding work. The station can work with an exhaust fan or with a filtering device.



BASE

BASE WITH COVERS

BASE WITH TOP EXTRACTION

The base of the stand is adapted for the installation of guards and a top extraction set. Each version of the grinding and welding station consists of a working table with a top made of 8 mm thick sheet metal. The top has $\varnothing 28$ mm mounting holes in a 100x100 mm grid and additional holes for dust and gas extraction.

The grinding and welding workstation with covers has a back cover, while the version with top extraction has a top extraction enclosure. Both of these versions (with guards and with top extraction) are equipped with hinged doors on the right and left sides - this makes it possible to place on the table workpieces longer than the width of the grinding and welding station.

Each version of the SOG has a connection spigot $\varnothing 160$ mm mounted in the side surface of the extraction tub. Air can be extracted from below through the extraction sump table. All types of grinding-welding station have an extraction tub with drawers, two 230V sockets for connecting power tools, and an installation for connecting workspace lighting.

For GPPH grinding and welding stations, you will use PLUS series tools mounted with ECO/PLUS adjustable mandrel.



GRINDING-WELDING STATION

SOG series

TECHNICAL PARAMETERS AND PRICE LIST

PARAMETERS FOR A TABLETOP WITH DIMENSIONS:	1270 x 770 mm	1870 x 770 mm
BASE		
Weight	167 kg	225 kg
Flow resistance	250 Pa	250 Pa
Recommended airflow	1220 m ³ /h	1220 m ³ /h
Maximum airflow	2440 m ³ /h	2440 m ³ /h
BASE WITH COVERS		
Weight	190 kg	250 kg
Flow resistance	250 Pa	250 Pa
Recommended airflow	1220 m ³ /h	1220 m ³ /h
Maximum airflow	2440 m ³ /h	2440 m ³ /h
BASE WITH TOP EXTRACTION		
Weight	264 kg	315 kg
Flow resistance	250 Pa	250 Pa
Recommended airflow	2440 m ³ /h	2440 m ³ /h
Maximum airflow	4880 m ³ /h	4880 m ³ /h

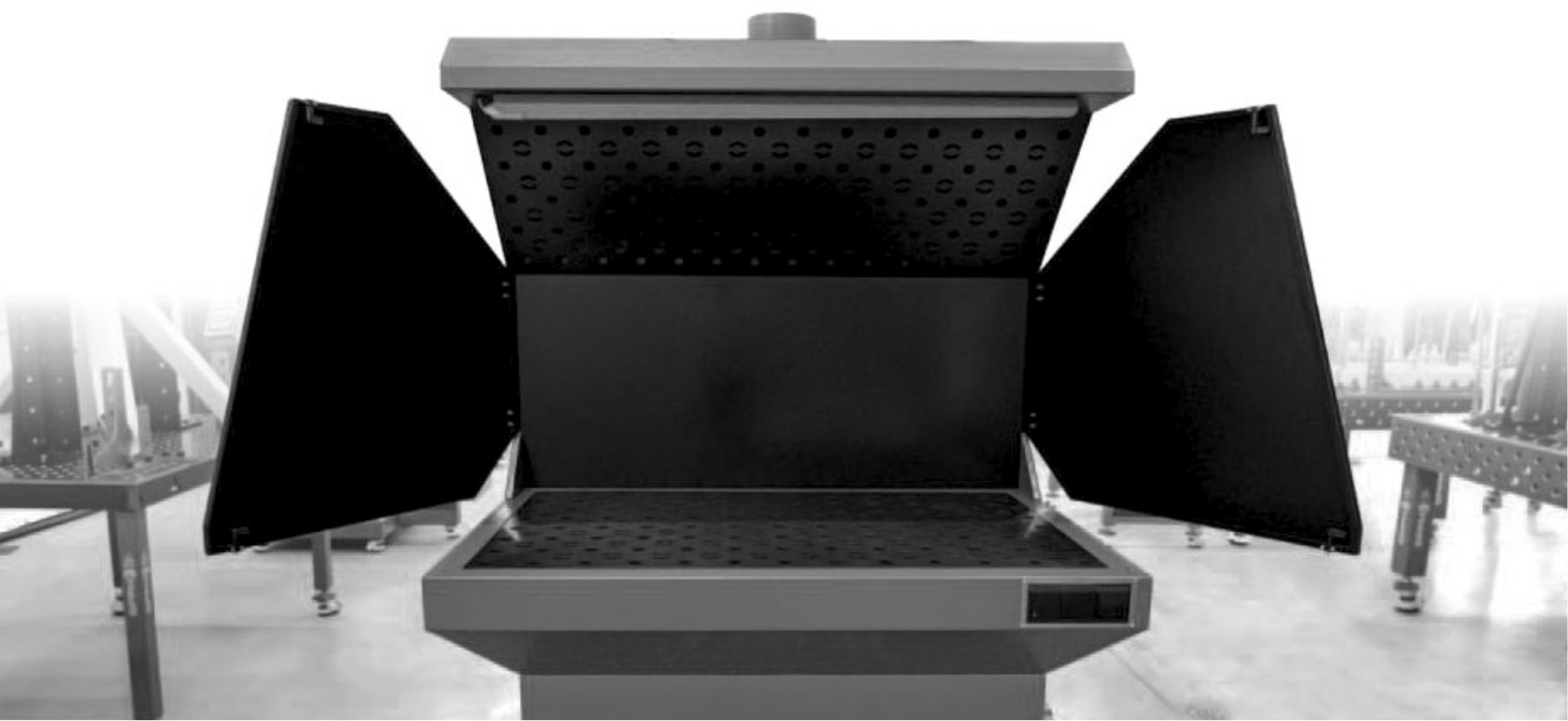



WELDING SUPPORTS



WELDING SUPPORTS

TRESTLE series

TECHNICAL PARAMETERS

TRESTLE welding support is the foundation for a variety of welding projects and more. Our welding support is an indispensable tool that can be used for many industries and purposes.

GPPH welding supports come in four series: **EXPERT**, **PRO**, **PLUS** and **ECO**.

THE MAIN APPLICATIONS OF THE TRESTLE WELDING SUPPORT INCLUDE:

INCREASING THE WORKING AREA: Thanks to its sturdy design, our support allows you to expand your working space, enabling more ergonomic and comfortable working conditions during welding.

A STABLE BASE FOR WELDING PROJECTS: Our support provides the stability and sturdiness necessary to carry out precise and complex welding projects. It is an invaluable support for professional welders and anyone looking for a solid base for their work.

SUPPORT FOR ASSEMBLY WORK: The welding support can also be used as a stable platform for assembling a variety of structural components, making assembly processes easier and faster.



All supports come in versions with feet on feet or on wheels.

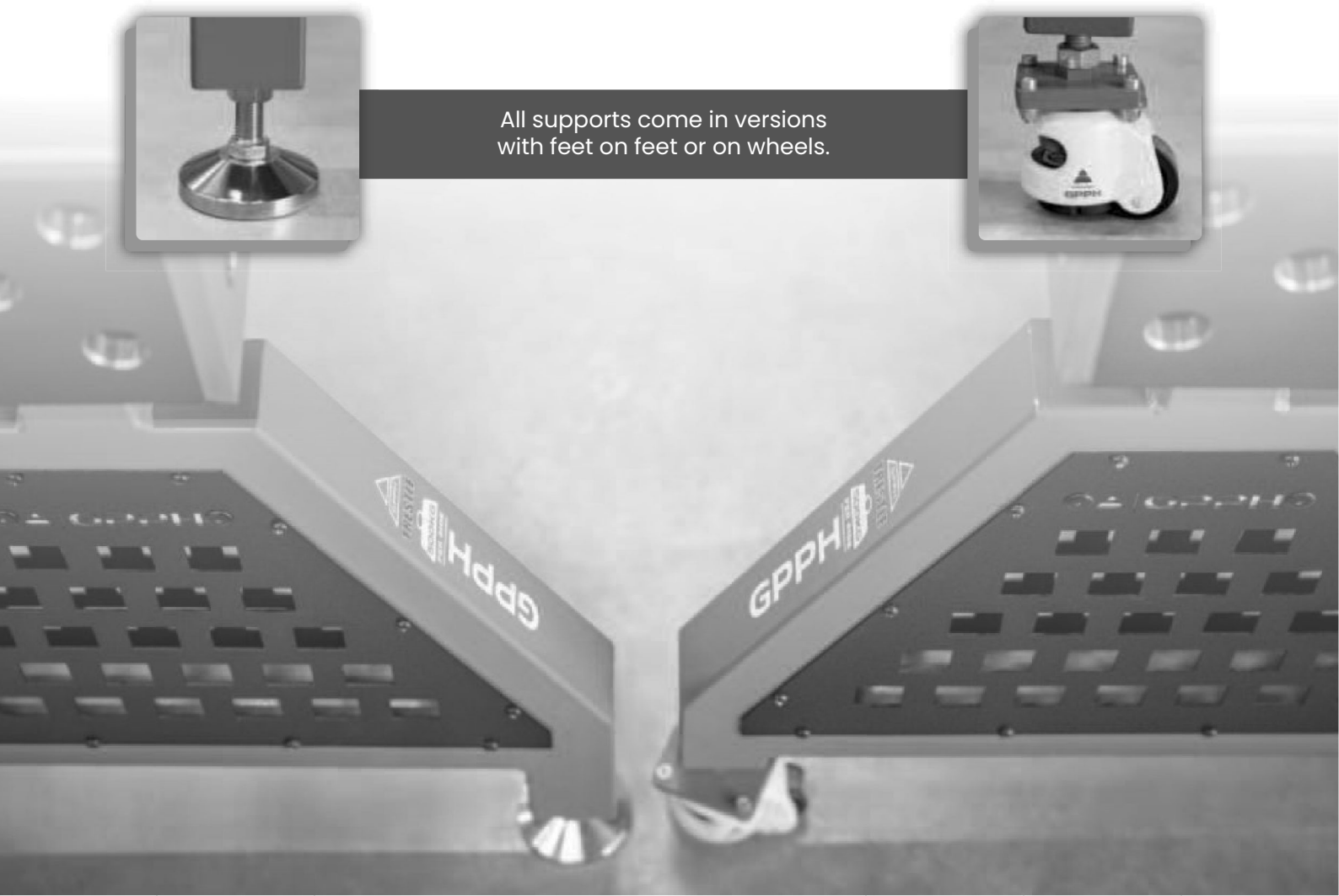

WELDING SUPPORTS

TRESTLE series

TECHNICAL PARAMETERS

	PRO	PLUS	ECO
GRID	HOLE SYSTEM		
	Ø 28 mm		Ø 16 mm
	DIAGONAL		50 x 50
			DIAGONAL

EXPERT	
GRID	HOLE SYSTEM
	Ø 28 mm
	DIAGONAL

DIMENSIONS OF TRESTLE SUPPORTS [mm]

600x200x200	600x400x200
800x200x200	800x400x200
1000x200x200	1000x400x200
1200x200x200	1200x400x200
1500x200x200	1500x400x200
2000x200x200	2000x400x200
2400x200x200	2400x400x200
3000x200x200	3000x400x200

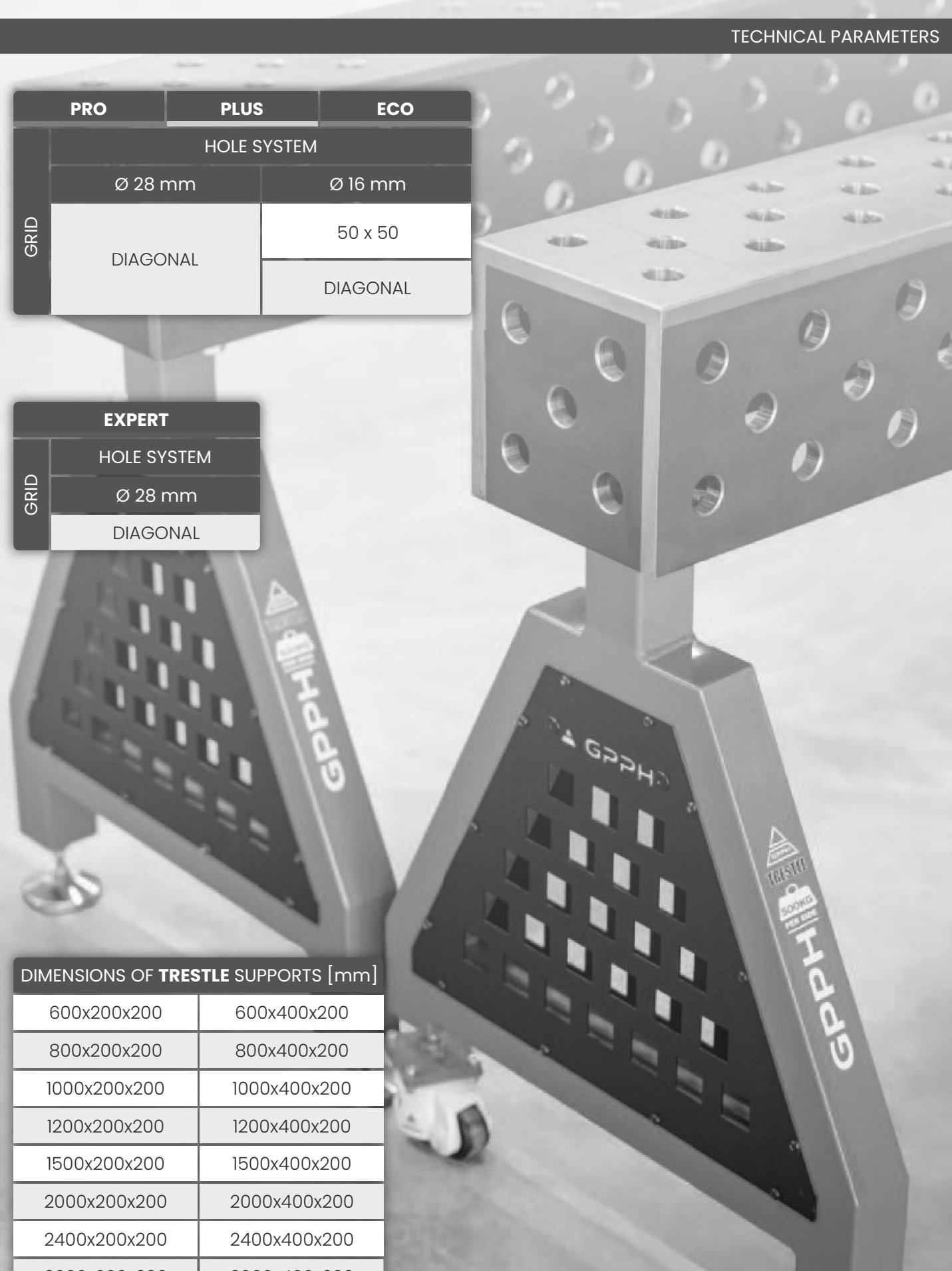





WELDING SUPPORTS

TRESTLE series



PRICE LIST

Price list for welding supports with a top made of S355J2+N steel with a system of holes \varnothing 28 mm and \varnothing 16 mm in the diagonal grid on the feet:



DIMENSIONS [mm]	 		   	
	EXPERT	PRO	PLUS	ECO
600x200x200				
800x200x200				
1000x200x200				
1200x200x200				
1500x200x200				
2000x200x200				
2400x200x200				
3000x200x200				

Price list for welding supports with top made of S355J2+N steel with \varnothing 16 mm hole system in 50x50 mm grid on feet:

DIMENSIONS [mm]	 		
	PRO	PLUS	ECO
600x200x200			
800x200x200			
1000x200x200			
1200x200x200			
1500x200x200			
2000x200x200			
2400x200x200			
3000x200x200			











WELDING SUPPORTS



TRESTLE series

PRICE LIST

Price list for welding supports with a top made of S355J2+N steel with a system of holes Ø 28 mm and Ø 16 mm in the diagonal grid on wheels:

DIMENSIONS [mm]	 		   	
	EXPERT	PRO	PLUS	ECO
600x200x200				
800x200x200				
1000x200x200				
1200x200x200				
1500x200x200				
2000x200x200				
2400x200x200				
3000x200x200				

Price list for welding supports with a top made of S355J2+N steel with a system of holes Ø 16 mm in 50x50 mm grid on wheels:

DIMENSIONS [mm]	 		
	PRO	PLUS	ECO
600x200x200			
800x200x200			
1000x200x200			
1200x200x200			
1500x200x200			
2000x200x200			
2400x200x200			
3000x200x200			

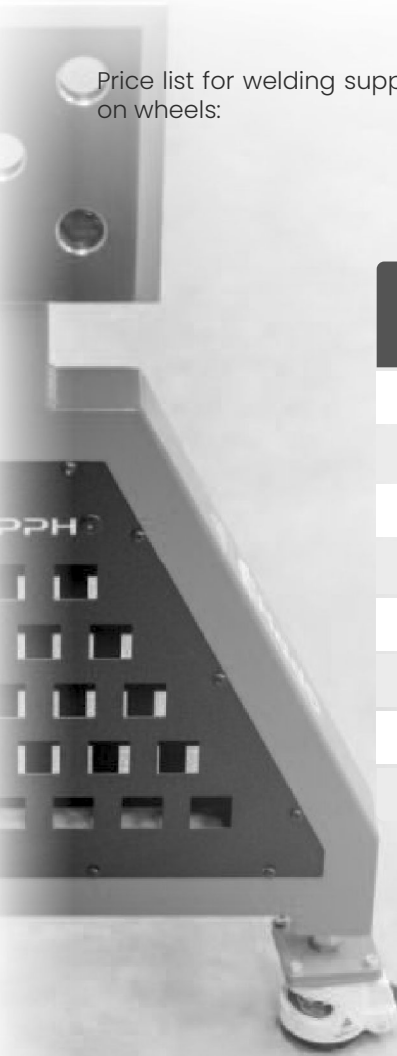



WELDING SUPPORTS

TRESTLE series

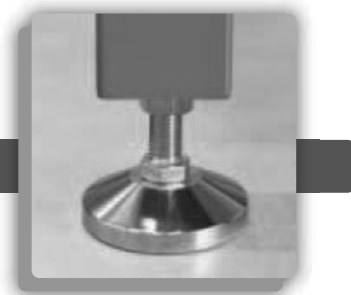

PRICE LIST

Price list for welding supports with a top made of S355J2+N steel with a system of holes \varnothing 28 mm and \varnothing 16 mm in the diagonal grid on the feet:



DIMENSIONS [mm]	 		   	
	EXPERT	PRO	PLUS	ECO
600x400x200				
800x400x200				
1000x400x200				
1200x400x200				
1500x400x200				
2000x400x200				
2400x400x200				
3000x400x200				

Price list for welding supports with a top made of S355J2+N steel with a system of holes \varnothing 16 mm in 50x50 mm grid on the feet:

DIMENSIONS [mm]	 		
	PRO	PLUS	ECO
600x400x200			
800x400x200			
1000x400x200			
1200x400x200			
1500x400x200			
2000x400x200			
2400x400x200			
3000x400x200			







WELDING SUPPORTS

TRESTLE series

PRICE LIST

Price list for welding supports with a top made of S355J2+N steel with a system of holes Ø 28 mm and Ø 16 mm in a 100x100 mm grid on wheels:

DIMENSIONS [mm]			 	
	EXPERT	PRO	PLUS	ECO
600x400x200				
800x400x200				
1000x400x200				
1200x400x200				
1500x400x200				
2000x400x200				
2400x400x200				
3000x400x200				

Price list for welding supports with a top made of S355J2+N steel with a system of holes Ø 16 mm in 50x50 mm grid on wheels:

DIMENSIONS [mm]			
	PRO	PLUS	ECO
600x400x200			
800x400x200			
1000x400x200			
1200x400x200			
1500x400x200			
2000x400x200			
2400x400x200			
3000x400x200			





WELDING BLOCKS



GPPH

GPPH
PRO
700KG
PER LEG
GPPH

WELDING BLOCKS

TECHNICAL PARAMETERS

Welding blocks are tools that are designed to connect two or more welding tables together, while maintaining functionality - just like a table top they have a grid and mounting holes. You can use them to create a custom-shaped welding station - combining any number of tables to create a workstation tailored to a particular project.

The cubes can be used alone or with legs as **TRESTLE** welding support (applies to 200 mm and 400 mm wide blocks).

DIMENSIONS OF WELDING BLOCKS [MM].		
600x100x100	600x200x200	600x400x200
800x100x100	800x200x200	800x400x200
1000x100x100	1000x200x200	1000x400x200
1200x100x100	1200x200x200	1200x400x200
1500x100x100	1500x200x200	1500x400x200
2000x100x100	2000x200x200	2000x400x200
2400x100x100	2400x200x200	2400x400x200
3000x100x100	3000x200x200	3000x400x200

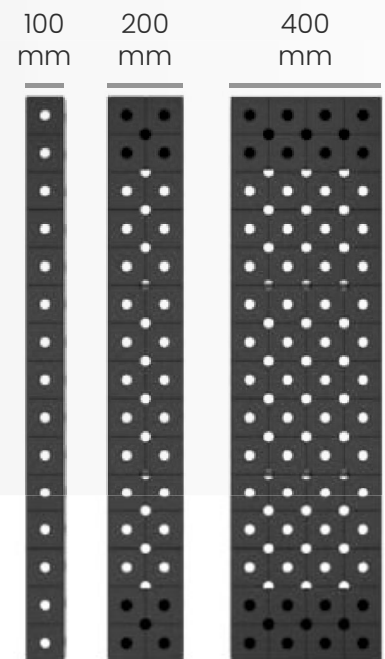

LEGS FROM TRESTLE SUPPORTS TO BE PURCHASED SEPARATELY ON FEET OR WHEELS:



Leg for welding support
TRESTLE on feet

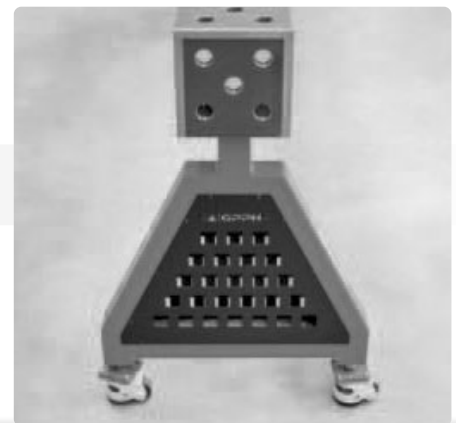

Leg for welding support
TRESTLE on wheels

WELDING BLOCKS

PRICE LIST

Price list for 100 mm wide welding blocks with Ø 28 mm and Ø 16 mm hole system in 100x100 mm grid:

DIMENSIONS [mm]				
	EXPERT	PRO	PLUS	ECO
600x100x100				
800x100x100				
1000x100x100				
1200x100x100				
1500x100x100				
2000x100x100				
2400x100x100				
3000x100x100				

Price list for 100 mm wide welding blocks with Ø 16 mm hole system in 50x50 mm grid:

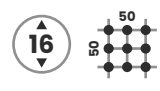
DIMENSIONS [mm]			
	PRO	PLUS	ECO
600x100x100			
800x100x100			
1000x100x100			
1200x100x100			
1500x100x100			
2000x100x100			
2400x100x100			
3000x100x100			



WELDING BLOCKS

PRICE LIST

Pricing for 200 mm wide welding blocks with \varnothing 28 mm and \varnothing 16 mm diagonal grid hole system:

DIMENSIONS [mm]				
	EXPERT	PRO	PLUS	ECO
600x200x200				
800x200x200				
1000x200x200				
1200x200x200				
1500x200x200				
2000x200x200				
2400x200x200				
3000x200x200				

Price list for welding blocks 200 mm wide with \varnothing 16 mm hole system in 50x50 mm grid:

DIMENSIONS [mm]			
	PRO	PLUS	ECO
600x200x200			
800x200x200			
1000x200x200			
1200x200x200			
1500x200x200			
2000x200x200			
2400x200x200			
3000x200x200			

WELDING BLOCKS

PRICE LIST

Pricing for 400 mm wide welding blocks with Ø 28 mm and Ø 16 mm hole system in diagonal grid:

DIMENSIONS [mm]	Ø 28 mm		Ø 16 mm	
	EXPERT	PRO	PLUS	ECO
600x400x200				
800x400x200				
1000x400x200				
1200x400x200				
1500x400x200				
2000x400x200				
2400x400x200				
3000x400x200				

Price list for 400 mm wide welding blocks with Ø 16 mm hole system in 50x50 mm grid:

DIMENSIONS [mm]	Ø 16 mm		
	PRO	PLUS	ECO
600x400x200			
800x400x200			
1000x400x200			
1200x400x200			
1500x400x200			
2000x400x200			
2400x400x200			
3000x400x200			

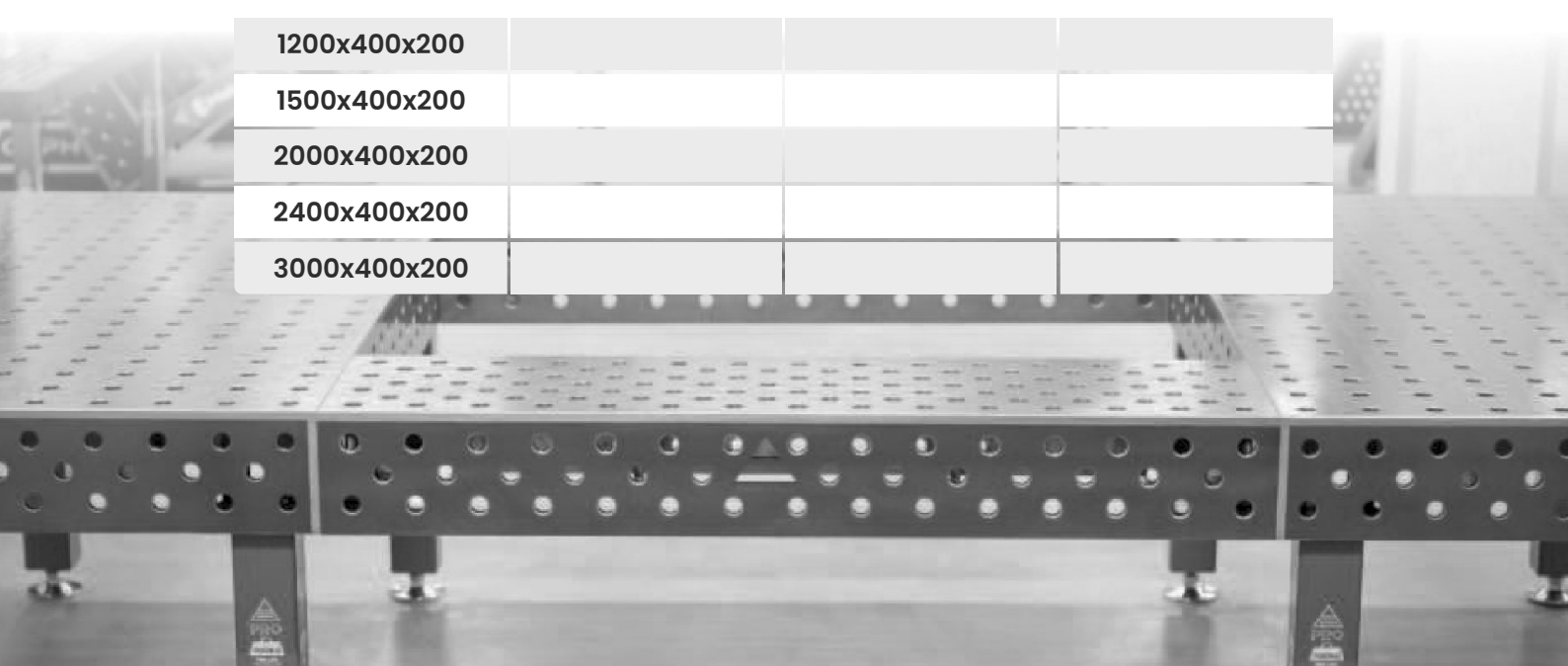

WELDING BLOCKS

WELDING BLOCKS WEIGHTS

DIMENSIONS [mm]	WEIGHT EXPERT	WEIGHT PRO	WEIGHT PLUS	WEIGHT ECO
600x100x100	30 kg	20 kg	15 kg	10 kg
800x100x100	40 kg	25 kg	20 kg	15 kg
1000x100x100	50 kg	30 kg	25 kg	20 kg
1200x100x100	60 kg	40 kg	30 kg	20 kg
1500x100x100	70 kg	50 kg	40 kg	30 kg
2000x100x100	100 kg	65 kg	50 kg	40 kg
2400x100x100	115 kg	80 kg	65 kg	45 kg
3000x100x100	145 kg	100 kg	80 kg	55 kg

600x200x200	75 kg	50 kg	40 kg	30 kg
800x200x200	100 kg	70 kg	55 kg	40 kg
1000x200x200	120 kg	80 kg	65 kg	45 kg
1200x200x200	140 kg	95 kg	80 kg	55 kg
1500x200x200	170 kg	115 kg	95 kg	65 kg
2000x200x200	220 kg	150 kg	120 kg	85 kg
2400x200x200	260 kg	180 kg	150 kg	100 kg
3000x200x200	350 kg	230 kg	190 kg	125 kg

600x400x200	145 kg	95 kg	75 kg	50 kg
800x400x200	170 kg	110 kg	90 kg	60 kg
1000x400x200	205 kg	135 kg	110 kg	75 kg
1200x400x200	235 kg	150 kg	120 kg	80 kg
1500x400x200	280 kg	185 kg	150 kg	100 kg
2000x400x200	355 kg	235 kg	190 kg	130 kg
2400x400x200	415 kg	275 kg	225 kg	150 kg
3000x400x200	505 kg	335 kg	270 kg	185 kg

*These are approximate values.

WELDING TABLE CONNECTORS



WELDING TABLE CONNECTORS

TECHNICAL PARAMETERS

Welding table connectors are an indispensable element in any professional welding workshop. They enable stable and precise connection of two welding tables or welding table with **TRESTLE** welding support, which allows to maintain constant distances and precise dimensions of welded structures.

ADVANTAGES AND FUNCTIONALITIES:

FIXED DISTANCE: They ensure that the distance between the tables or supports to be joined is always the same, which is crucial for precision and repeatability in welding.

MULTITASKING: They fit both welding tables and TRESTLE welding supports, making them a versatile solution for many work situations.

WIDE SELECTION OF SIZES: Available in 20 different sizes, from 100mm to 2000mm in 100mm increments, allowing for a perfect fit for each user.

MATERIALS AND BUILD QUALITY

The connectors are made of high-quality materials, which ensures their durability and resistance to mechanical damage and corrosion. Precision machining makes them fit perfectly on tables and supports, guaranteeing stability and safety during work.

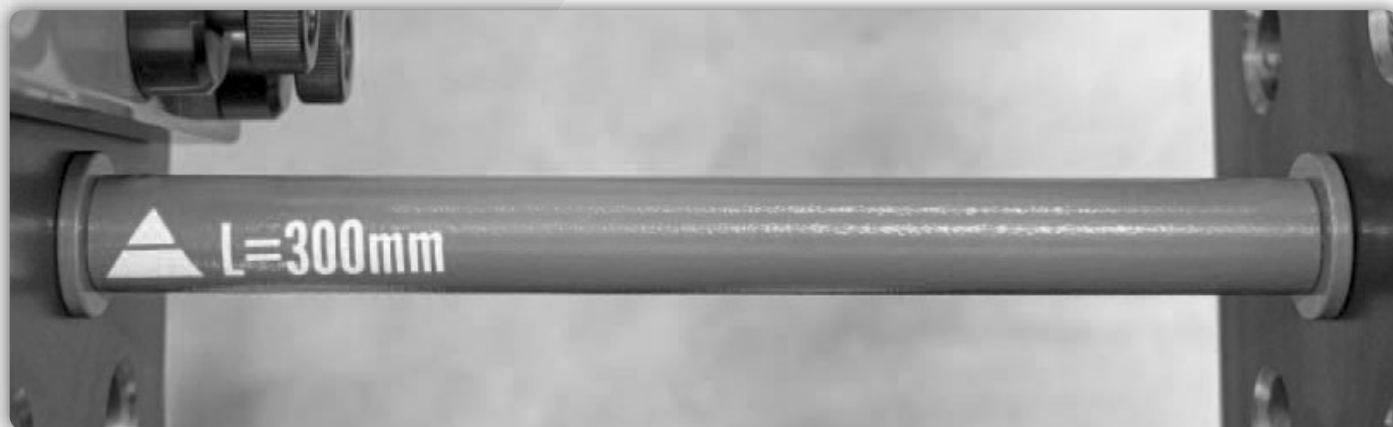

IDEAL SOLUTION FOR YOUR WORKSHOP

Choosing the right fasteners is a guarantee of accuracy and reliability in any welding project. A wide range of sizes allows you to match fasteners to different applications, and their high quality workmanship ensures the longevity of the product.

WELDING TABLE CONNECTORS

DIMENSIONS AND PRICE LIST

DIMENSIONS [mm]	
100	
200	
300	
400	
500	
600	
700	
800	
900	
1000	
1100	
1200	
1300	
1400	
1500	
1600	
1700	
1800	
1900	
2000	

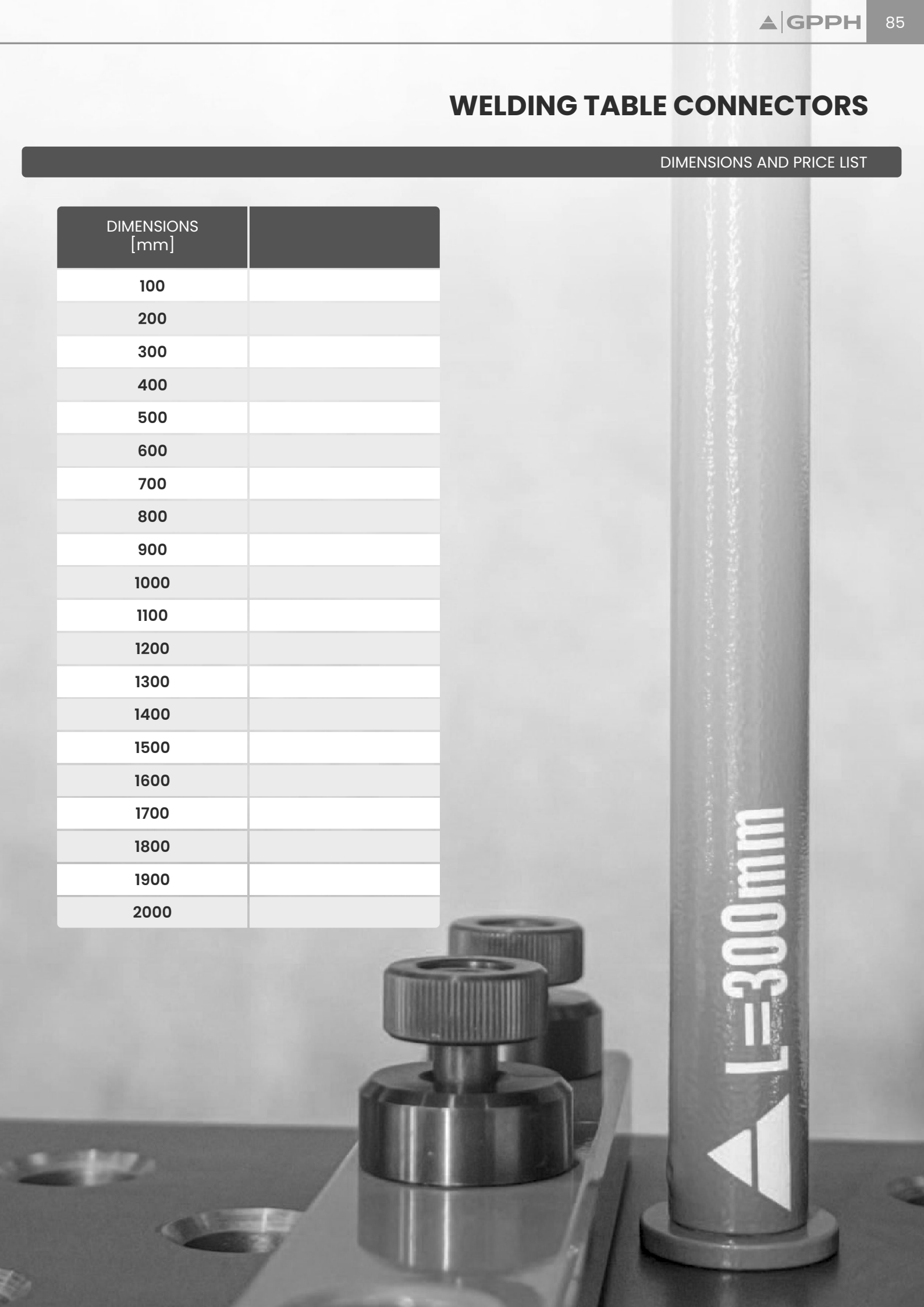

L=300mm





RAIL SYSTEMS FOR WELDING TABLES AND SUPPORTS

GPPH
SLIDE SYSTEM



RAIL SYSTEMS FOR WELDING TABLES AND SUPPORTS

SLIDE SYSTEM series

TECHNICAL PARAMETERS

The GPPH rail system is a proposal of our brand, designed to optimize welding and assembly processes in workshops and production facilities. Dedicated to welding tables and **TRESTLE** welding supports, it allows precise clamping and easy movement of components, guaranteeing a stable and repeatable position during processing.

BENEFITS OF IMPLEMENTING A GPPH RAIL SYSTEM:

INCREASING EFFICIENCY: Reduce the time needed to prepare the site and reduce downtime.

FLEXIBLE FIT: To the size and nature of the projects – quick adaptation of the position to new production tasks.

OPTIMAL USE OF SPACE: System components can be combined in various configurations to better manage space constraints.

MINIMIZING ERRORS: Assembly thanks to stable, secure mounts and precise positioning.

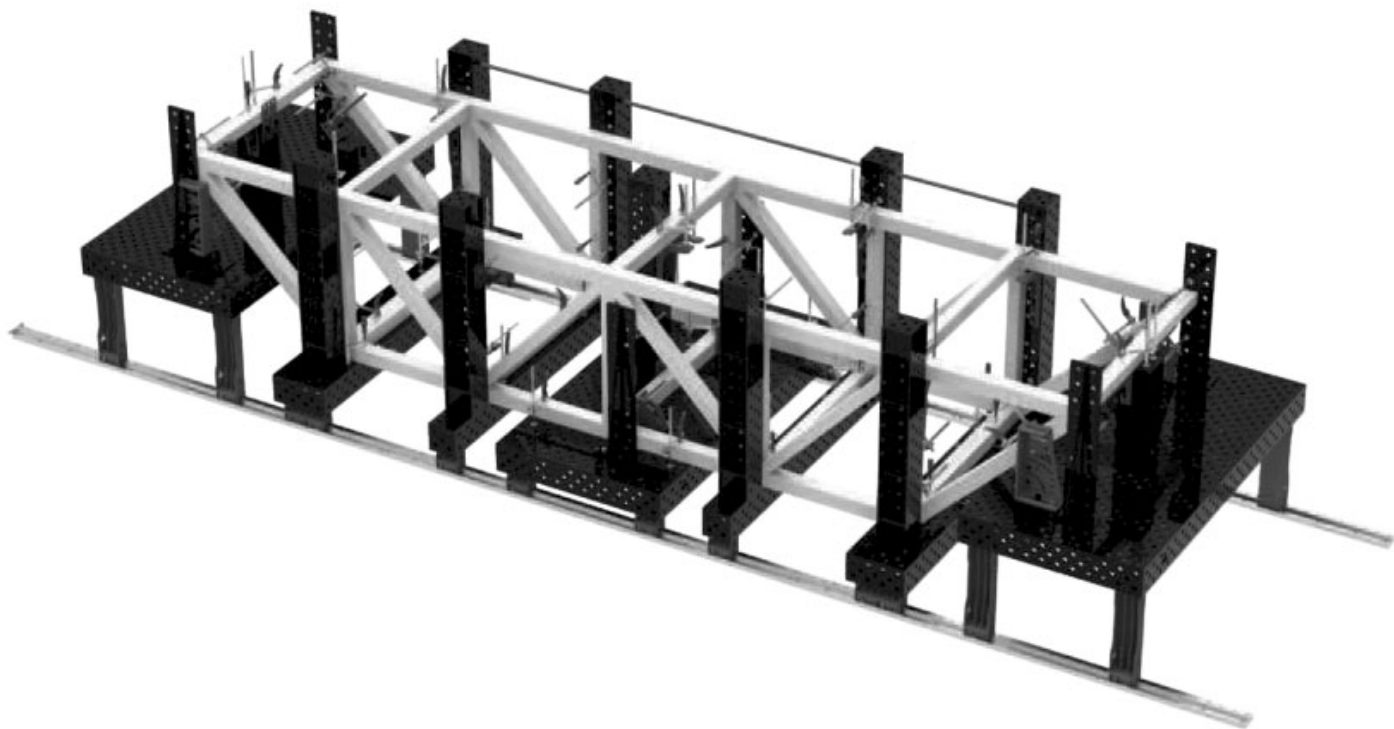

The rail system can be configured modularly, selecting its length in 1m increments (the minimum installation length is 2 m). In terms of width, it is possible to install only elements of identical working width – for example, blocks of 2000x400 can also be attached to the 2000x1000 table. 2000x200, but it is not possible to use other formats, such as 1000x400 or 1500x200.

RAIL SYSTEMS FOR WELDING TABLES AND SUPPORTS

SLIDE SYSTEM series

TECHNICAL PARAMETERS

Key features of the GPPH rail system:

Versatility of application

- Ability to mount both welding tables and welding supports on the same rails.
- System designed to work well in different types of workshops and production lines.

Easy adjustment and positioning

- Smooth movement of the tables or supports along the rails makes it possible to quickly change the configuration of the workstation.
- Built-in locking mechanisms allow you to instantly immobilize the table/support in the desired location.

Modular design

- The solution consists of components that can be easily expanded and adapted to the size of the production floor and the specifics of the processes being carried out.
- The rails can be extended or combined in different configurations to create an optimal working environment.

High precision and stability

- Precision guides and robust construction ensure the accuracy of the findings and the absence of vibration during processing.
- Thanks to the use of high-quality materials, the system is characterized by high resistance to loads and conditions in industrial plants.

Ergonomics and safety

- The system's design allows ergonomic positioning of the table or support, which facilitates access to welded parts and improves operator comfort.

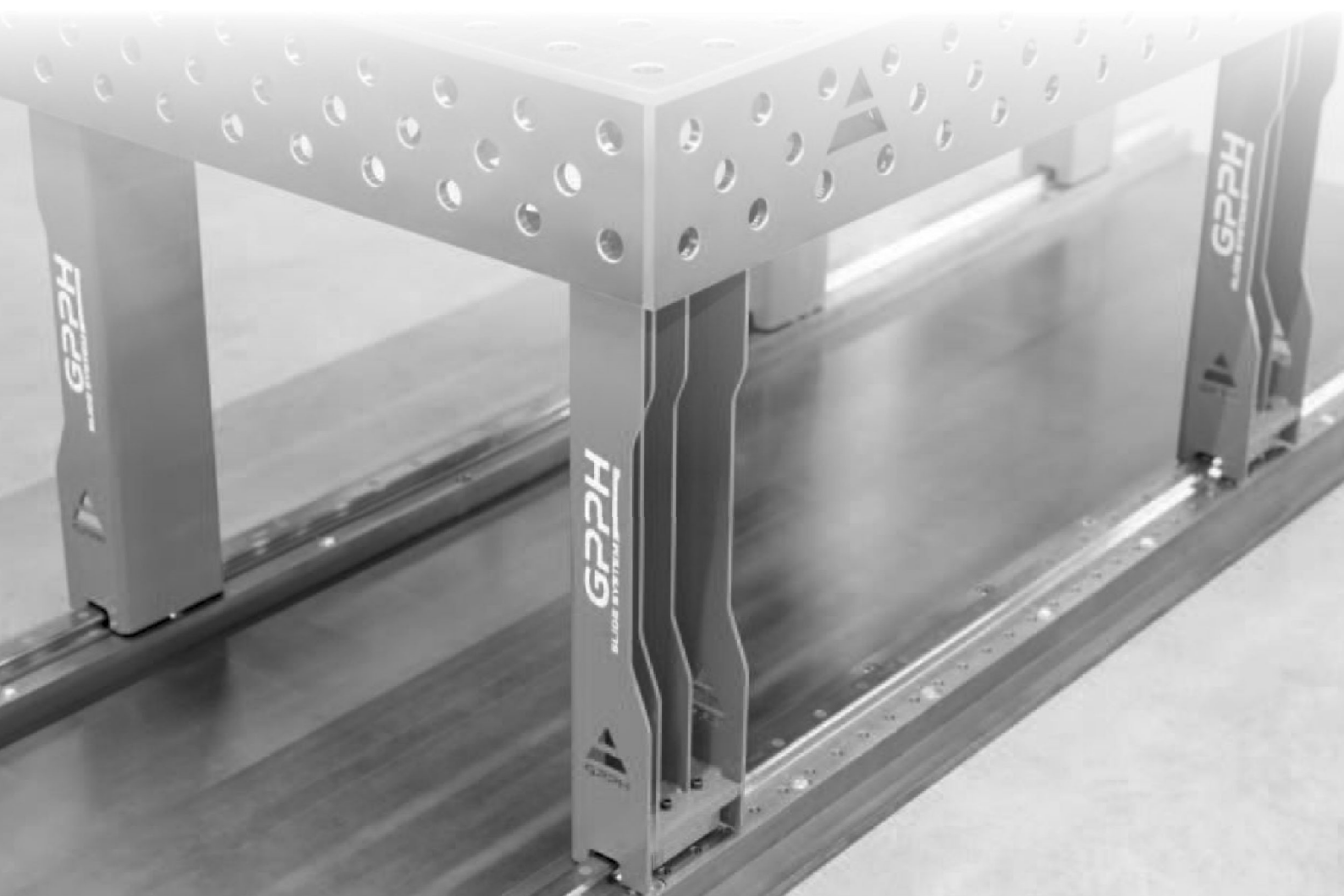

RAIL SYSTEMS FOR WELDING TABLES AND SUPPORTS

SLIDE SYSTEM series

TECHNICAL PARAMETERS AND PRICE LIST

A choice of 350 mm high platform rail legs allows convenient welding of large-scale structures. The lowered platform provides better access to components, facilitating precise and efficient work.

The rail system can be installed at the standard height of welding tables - 870 mm, providing optimal working conditions. This height guarantees ergonomics, comfort of use and easy access to tools, which translates into greater precision and productivity during welding.

The GPPH rail system is a reliable solution for professionals who demand versatility, durability and accuracy in welding and assembly. Thanks to its modular design and easy adjustment, it is an investment that will quickly pay for itself and streamline work in any manufacturing facility.

Foundation rail with **linear guide 2000**

Foundation rail with **linear guide 3000**

Foundation rail with **linear guide 4000**

*The price shown is the price for one rail. For the whole installation to work properly, you need to buy at least double the number of rails.

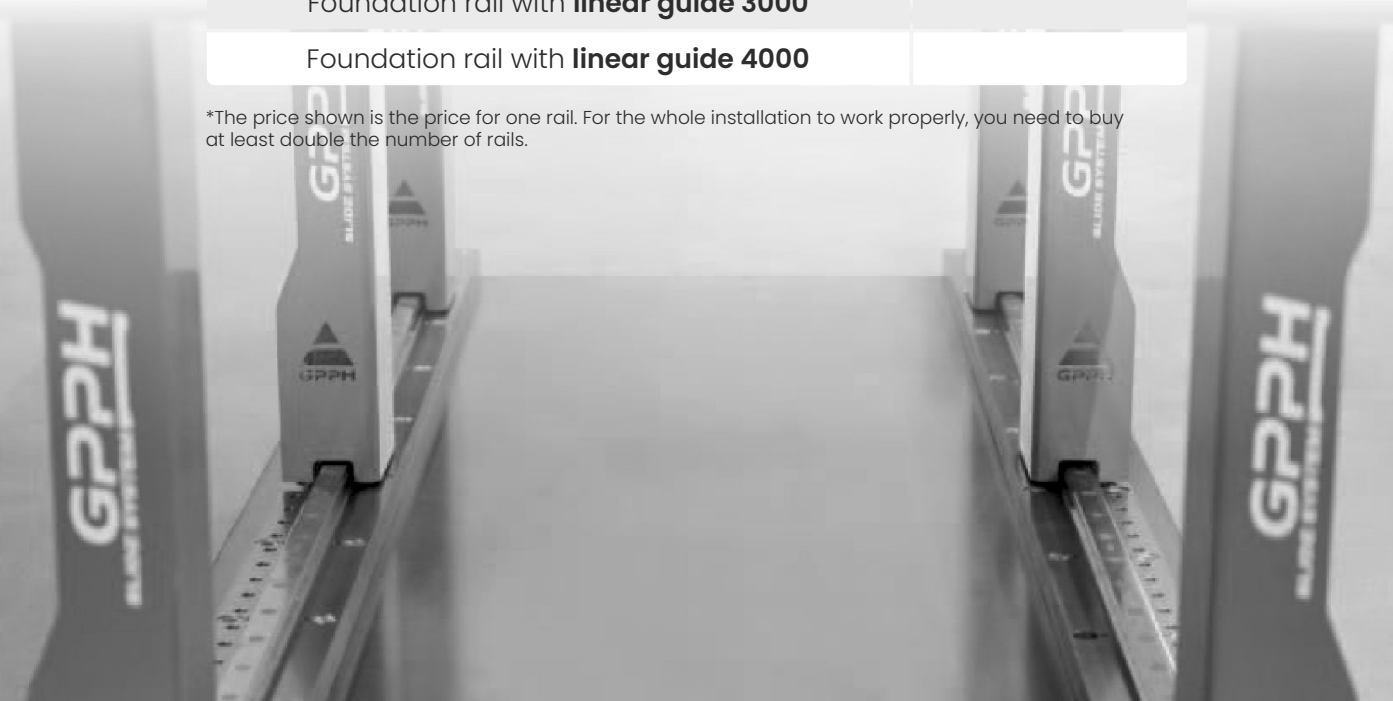







RAIL SYSTEMS FOR WELDING TABLES AND SUPPORTS









SLIDE SYSTEM series

DIMENSIONS AND PRICE LIST

Price list for table top rail system with hole system Ø 28 mm and Ø 16 mm in a 100x100 mm grid with high legs:

DIMENSIONS [mm]	 	 		 	
	EXPERT	PRO	PRO INOX	PLUS	PLUS INOX
1000 x 600					
1000 x 1000					
1200 x 800					
1200 x 1000					
1200 x 1200					
1500 x 1000					
1500 x 1480					
2000 x 1000					
2400 x 1200					

Price list for table top rail system with hole system Ø 28 mm and Ø 16 mm in diagonal grid and Ø 16 mm in 50x50 mm grid with high legs:







DIMENSIONS [mm]	 	 		 		 	
	EXPERT	PRO	PRO INOX	PLUS	NET PRICE PLUS INOX		
1000 x 600							
1000 x 1000							
1200 x 800							
1200 x 1000							
1200 x 1200							
1500 x 1000							
1500 x 1480							
2000 x 1000							
2400 x 1200							

RAIL SYSTEMS FOR WELDING TABLES AND SUPPORTS



SLIDE SYSTEM series

DIMENSIONS AND PRICE LIST

Price list for the 200 mm wide welding support rail system with a hole system of \varnothing 28 mm and \varnothing 16 mm in a diagonal grid with high legs:

DIMENSIONS [mm]	 	 	 
	EXPERT	PRO	PLUS
600x200x200			
800x200x200			
1000x200x200			
1200x200x200			
1500x200x200			
2000x200x200			
2400x200x200			
3000x200x200			

Price list for the rail system for 200 mm wide welding supports with a hole system \varnothing 16 mm in a 50x50 mm grid with high legs:







DIMENSIONS [mm]	 	
	PRO	PLUS
600x200x200		
800x200x200		
1000x200x200		
1200x200x200		
1500x200x200		
2000x200x200		
2400x200x200		
3000x200x200		

RAIL SYSTEMS FOR WELDING TABLES AND SUPPORTS



SLIDE SYSTEM series

DIMENSIONS AND PRICE LIST

Price list for the 400 mm wide welding support rail system with a hole system of Ø 28 mm and Ø 16 mm in a diagonal grid with high legs:

DIMENSIONS [mm]	 	 	 
	EXPERT	PRO	PLUS
600x400x200			
800x400x200			
1000x400x200			
1200x400x200			
1500x400x200			
2000x400x200			
2400x400x200			
3000x400x200			

Price list for the rail system for 400 mm wide welding supports with a hole system Ø 16 mm in a 50x50 mm grid with high legs:







DIMENSIONS [mm]	 	
	PRO	PLUS
600x400x200		
800x400x200		
1000x400x200		
1200x400x200		
1500x400x200		
2000x400x200		
2400x400x200		
3000x400x200		

RAIL SYSTEMS FOR WELDING TABLES AND SUPPORTS









SLIDE SYSTEM series

DIMENSIONS AND PRICE LIST

Price list for table top rail system with hole system \varnothing 28 mm and \varnothing 16 mm in a 100x100 mm grid with low legs:

	 	 		 	
DIMENSIONS [mm]	EXPERT	PRO	PRO INOX	PLUS	PLUS INOX
1000 x 600					
1000 x 1000					
1200 x 800					
1200 x 1000					
1200 x 1200					
1500 x 1000					
1500 x 1480					
2000 x 1000					
2400 x 1200					

Price list for table top rail system with hole system \varnothing 28 mm and \varnothing 16 mm in diagonal grid and \varnothing 16 mm in 50x50 mm grid with low legs:







	 	 		 		 	
DIMENSIONS [mm]	EXPERT	PRO	PRO INOX	PLUS	PLUS INOX		
1000 x 600							
1000 x 1000							
1200 x 800							
1200 x 1000							
1200 x 1200							
1500 x 1000							
1500 x 1480							
2000 x 1000							
2400 x 1200							

RAIL SYSTEMS FOR WELDING TABLES AND SUPPORTS



SLIDE SYSTEM series

DIMENSIONS

Price list for the 200 mm wide welding support rail system with \varnothing 28 mm and \varnothing 16 mm hole pattern in a diagonal grid with low legs:

DIMENSIONS [mm]	 	 	 
	EXPERT	PRO	PLUS
600x200x200			
800x200x200			
1000x200x200			
1200x200x200			
1500x200x200			
2000x200x200			
2400x200x200			
3000x200x200			

Price list for the rail system for 200 mm wide welding supports with a hole system \varnothing 16 mm in a 50x50 mm grid with low legs:





DIMENSIONS [mm]	 	
	PRO	PLUS
600x200x200		
800x200x200		
1000x200x200		
1200x200x200		
1500x200x200		
2000x200x200		
2400x200x200		
3000x200x200		

RAIL SYSTEMS FOR WELDING TABLES AND SUPPORTS



SLIDE SYSTEM series

DIMENSIONS AND PRICE LIST

Price list for the 400 mm wide welding support rail system with \varnothing 28 mm and \varnothing 16 mm hole pattern in a diagonal grid with low legs:

DIMENSIONS [mm]	 	 	 
	EXPERT	PRO	PLUS
600x400x200			
800x400x200			
1000x400x200			
1200x400x200			
1500x400x200			
2000x400x200			
2400x400x200			
3000x400x200			

Price list for the rail system for 400 mm wide welding supports with a hole system \varnothing 16 mm in a 50x50 mm grid with low legs:

DIMENSIONS [mm]	 	
	PRO	PLUS
600x400x200		
800x400x200		
1000x400x200		
1200x400x200		
1500x400x200		
2000x400x200		
2400x400x200		
3000x400x200		

GPPH IQ AIR FLOW

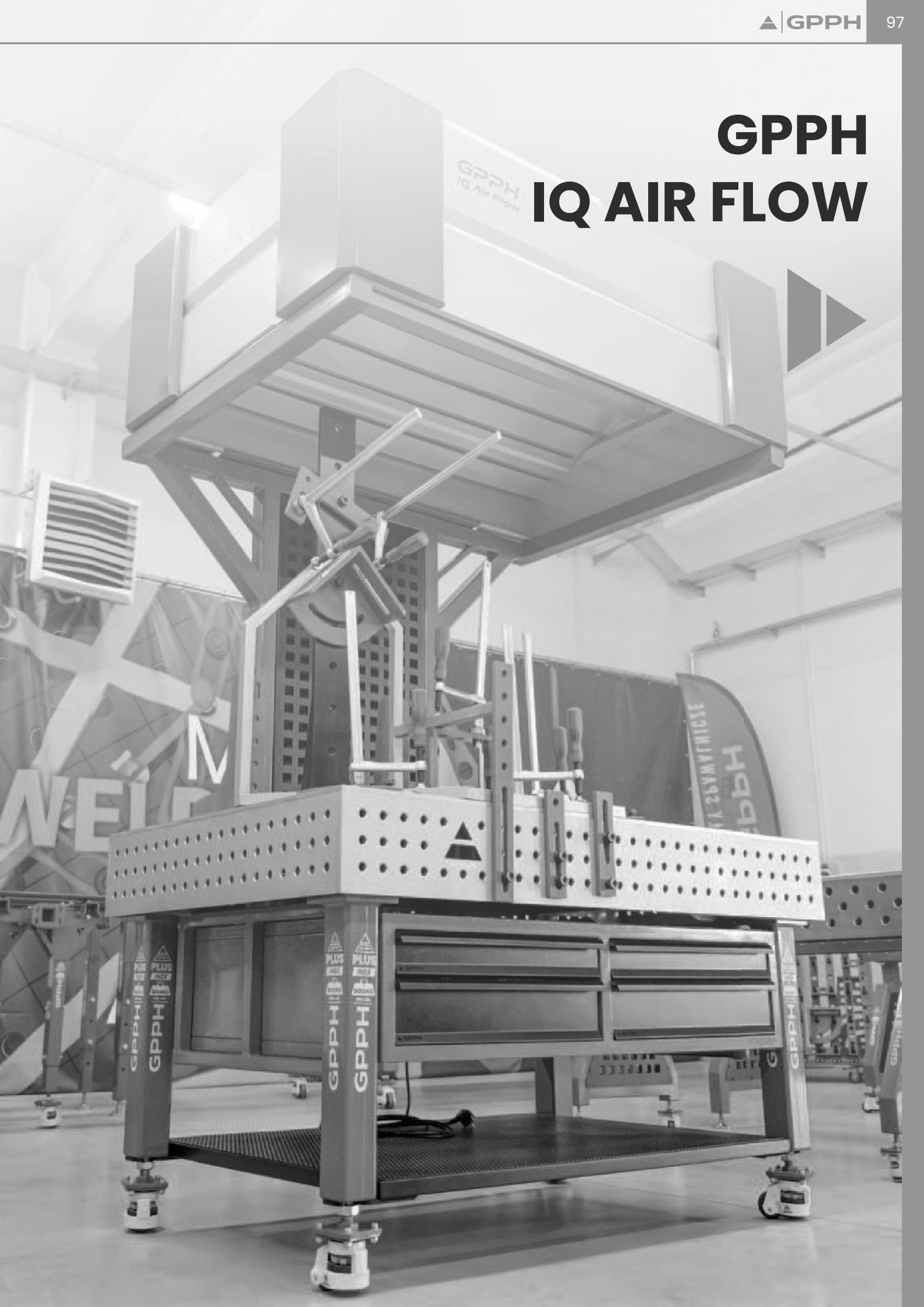

GPPH IQ AIR FLOW

welding hood with fan

TECHNICAL PARAMETERS

The innovative **GPPH IQ Air Flow** welding fume extractor hood is a modern solution that significantly raises health and safety standards in any welding workshop. Thanks to its unique design, the hood effectively extracts welding fumes from all sides of the table, including the corners, which ensures clean air in the workplace and protects the welder's health.

EFFICIENT SMOKE DRAINAGE: The welding hood is designed to effectively remove welding fumes from the entire table surface. Specially designed ventilation ducts allow for effective removal of contaminants, regardless of the work location, including the corners of the table.

IMPROVEMENT OF WORKING CONDITIONS: Thanks to the effective smoke extraction, welders do not have to breathe in harmful fumes, which significantly improves air quality and reduces the risk of health problems. This solution is crucial for maintaining occupational health and safety.

VERSATILITY AND FLEXIBILITY: The extractor hood is available with or without a fan, allowing the product to be customized to the customer's individual needs and preferences. The version with a fan ensures maximum smoke extraction efficiency, while the option without a fan allows for integration with the existing ventilation system.

EASY TO ASSEMBLE AND USE: The fume extraction hood is easy to install on different types of welding tables, making it a universal solution for various workshop configurations.



GPPH IQ AIR FLOW

welding hood with fan

TECHNICAL PARAMETERS AND PRICE LIST

TECHNICAL PARAMETERS OF THE FAN	
air circulation	2700 m ³ /h
air pressure	min 130 Pa
power	170 W
noise	max 85 dB
tension	230 V
weight	4,5 kg
material	powder coated S355 steel

*It is possible to order a version without a fan, in which case the amount of 80 EUR will be deducted from the basic price.

HOOD DIMENSIONS [mm]	RICE
1000 x 1000	
1200 x 1200	
1500 x 1000	
1500 x 1480	
2000 x 1000	
2400 x 1200	

The prices for all eaves frames are 990 EUR.



GPPH IQ AIR FLOW

welding hood with fan

TECHNICAL PARAMETERS

The welding fume extraction hood is made of durable materials that can withstand high temperatures and heavy use. Its design ensures maximum smoke extraction efficiency, and the availability of a version with a fan allows for immediate improvement of working conditions.

For customers who already have ventilation systems, we also offer the option of purchasing a hood without a fan.



Invention registered with the Polish Patent Office, application marked with the following numbers: P.450498, P.450499



A 300 mm diameter duct fan guarantees high performance



The aluminum construction ensures high corrosion resistance and easy assembly



LED lighting for optimal visibility during work

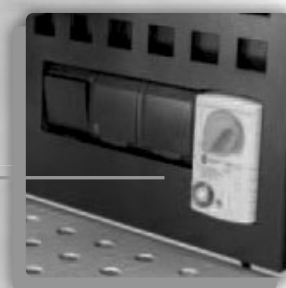

Infinitely variable fan speed control

IQ AERO CLEAN - FILTERING AND VENTILATION EQUIPMENT



GPPH
IQ Aero Clean
mobile 1.0

IQ AERO CLEAN

filtering and ventilation equipment

TECHNICAL PARAMETERS

Clean air at the workplace is essential, especially in a welding environment. That is why GPPH presents IQ Aero Clean - a modern welding extractor that effectively eliminates smoke and pollutants generated during welding. Thanks to an advanced filtration system, the device not only improves work comfort, but above all, it takes care of the health of employees and the cleanliness of the production hall.

WHY CHOOSE IQ AERO CLEAN?

EFFECTIVE FILTRATION: An advanced filter system cleans the air, eliminating harmful particles and improving working conditions.

FLEXIBILITY AND MOBILITY: The mobile and wall versions allow for adaptation to different workplaces and needs.

INTEGRATION WITH IQ AIR FLOW: Option to combine Mobile 1.0 with our welding hood for even better performance.

ERGONOMICS AND COMFORT: Easy to use, compact design and durable for years.

IQ AERO CLEAN

because clean air
means better work.

IQ AERO CLEAN

filtering and ventilation equipment

TECHNICAL PARAMETERS

FOUR VERSIONS TO SUIT YOUR NEEDS

IQ Aero Clean is an extraction system available in four versions to suit the specific requirements of any welding shop:

IQ Aero Clean Mobile 1.0 – a stationary or mobile version that can be connected to our IQ Air Flow welding fume extractor using a 315 mm diameter ventilation pipe, thus creating a comprehensive ventilation system for professional welding stations.

IQ Aero Clean Mobile 2.0 – a stationary or mobile version equipped with two flexible extraction arms (“elephants”) that allow the extraction to be precisely positioned anywhere. This allows two welding stations to be operated simultaneously, making it ideal for changing work conditions.

IQ Aero Clean Wall 1.0 – a wall-mounted extraction system with one extraction arm. Its stationary design allows for effective welding fume extraction without taking up floor space, which facilitates the organization of workstations. The device can also be connected to our IQ Air Flow welding hood with a 315 mm ventilation pipe to create a comprehensive ventilation system for professional welding workplaces.

IQ Aero Clean Wall 2.0 – a wall-mounted system with two extraction arms on either side. This allows two welding stations to be operated simultaneously, optimizing space and effectively eliminating smoke from the production hall. Wall mounting is an additional advantage because it saves floor space, facilitates the organization of workstations and eliminates the need to move the device, which increases work comfort and efficiency.



IQ AERO CLEAN

filtering and ventilation equipment

TECHNICAL PARAMETERS

TECHNICAL SPECIFICATIONS FOR ALL IQ AERO CLEAN VERSIONS:

Air flow capacity	6000 m ³ /h
Filtration type	spark arrestor filter + cartridge filter with a surface area of 20m ²
Filtration level	99,5% for particles with a size of 0,3 µm
Noise level	40% - 60 dB 100% - 80 dB*
Engine power	1,5 kW
Power supply	400 V
Material	powder-coated steel
IQ Flow Control system	adaptive air flow regulation

*Noise level measured in close proximity to the device casing.

Dust-proof system with a grid in the drawers – prevents the secondary lifting of contaminants during operation, ensuring a cleaner and safer environment and a longer filter life.

Pulse-jet cleaning system – uses short, intense pulses of compressed air that reverse the air flow in the filter, effectively removing accumulated dust from the surface of the filter cartridges; additional possibility to program the frequency of the system operation.

The device is equipped with a professional air filter with a reducer – the pneumatic system does not need to be prepared for installation of the device.

The device is equipped with a vacuum gauge to monitor the degree of filter contamination – enabling quick detection of a drop in performance by signaling the approaching level of filter clogging.



IQ AERO CLEAN

filtering and ventilation equipment

TECHNICAL PARAMETERS AND PRICE LIST

IQ Aero Clean mobile 1.0	IQ Aero Clean mobile 2.0
IQ Air Flow connection option	Flexible extraction arm ("elephant")
Stationary or mobile assembly	Stationary or mobile assembly
Dimensions: 1830x1000x650 mm	Dimensions: 1830x1000x650 mm
Weight: 200 kg	Weight: 200 kg

IQ Aero Clean wall 1.0	IQ Aero Clean wall 2.0
IQ Air Flow connection option	Flexible extraction arm ("elephant")
Wall mounting	Wall mounting
Dimensions: 1560x1420x720 mm	Dimensions: 1560x1420x720 mm
Weight: 220 kg	Weight: 220 kg

*The dimensions and weights indicated refer to the device alone.
 **The prices of IQ Aero Clean Mobile devices do not include the extraction arms and ventilation pipes needed to connect the devices together.

PRICE LIST OF FLEXIBLE EXTRACTION ARMS ("TRUNKS")	
2-meter long extraction arm	
3-meter long extraction arm	
4-meter long extraction arm	



WELDING GATE

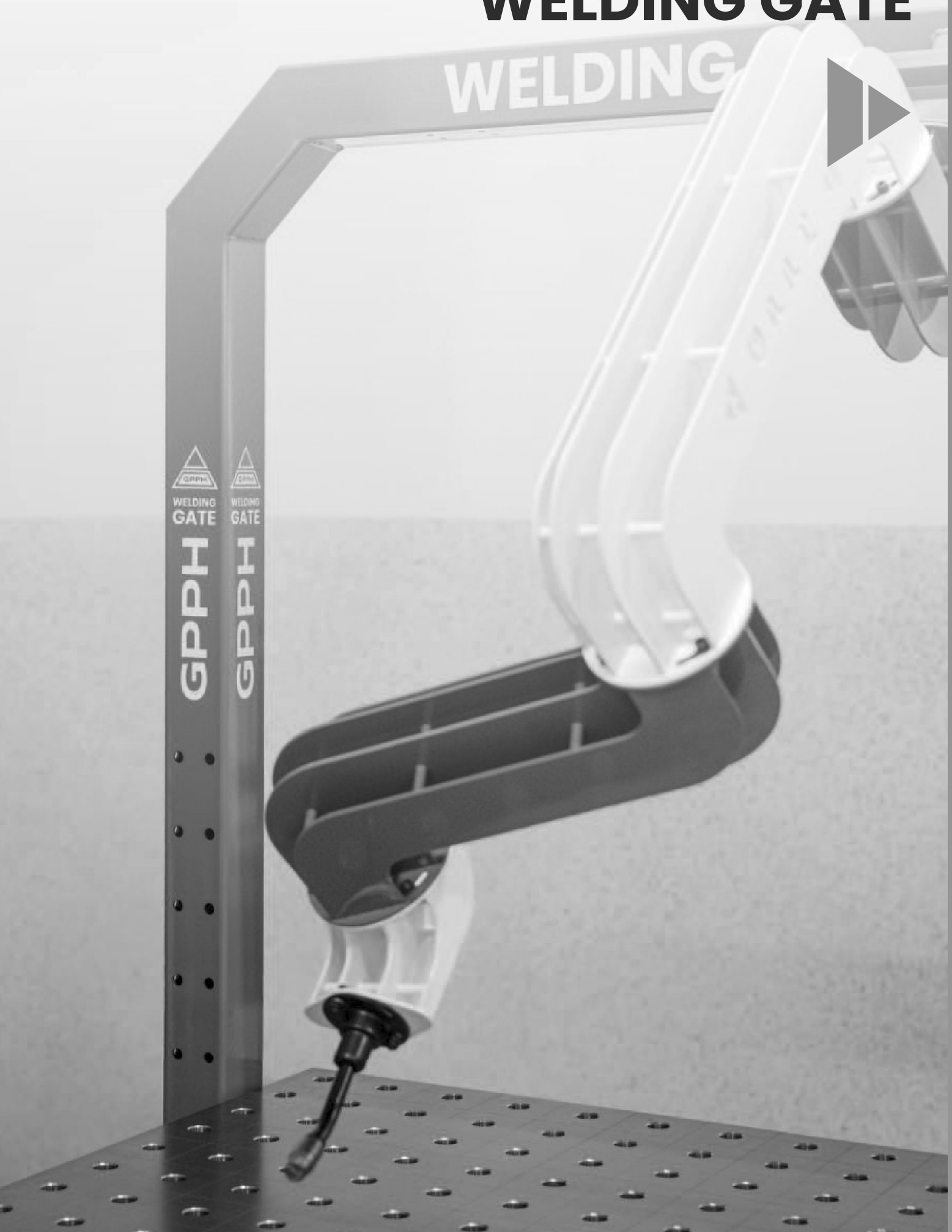

WELDING GATE

TECHNICAL PARAMETERS

The **Welding Gate** is an innovative solution that opens up new possibilities for automating welding processes. This frame enables stable and convenient attachment of cobots to welding tables, making it an ideal tool for modern production facilities.

KEY FEATURES:

VERSATILITY: The Welding Gate is compatible with various welding table models, ensuring flexibility of use in different industrial environments.

STABILITY: The robust design guarantees safe work with the cobot, even during intensive welding processes.

EASY INSTALLATION: The Welding Gate frame is designed to be quickly and easily attached to the welding table. Thanks to the sophisticated mounting system, installation only takes a few minutes.

WORK OPTIMIZATION: The Welding Gate allows you to fully utilize the capabilities of the cobot, ensuring smooth operation and precision with every welding operation. With the right settings, downtime is minimized and production processes become more efficient.

FUNCTIONAL DESIGN: The Welding Gate was designed for maximum performance in a production environment. Its robustness and well-thought-out design ensure stability and ease of use even in demanding industrial environments.



WELDING GATE

TECHNICAL PARAMETERS AND PRICE LIST

The Cobot in the **Welding Gate** can be attached to the welding table at a right angle or at a 45-degree angle, depending on the user's needs and the specifics of the welding process. The standard height of the **Welding Gate** frame from the welding table is 1200 mm, which ensures optimal working conditions and freedom of movement for the Cobot arm. It is possible to adjust the height of the frame to the dimensions of the attached cobot - to determine it, please contact our sales specialist.

When ordering, it is necessary to specify the dimension of the flange to which the cobot will be attached to the **Welding Gate** frame.

COMPARISON OF COBOARD MOUNTING AT 45° and 90°:



DIMENSIONS [mm]	WELDING GATE 45°	WELDING GATE 90°
1000		
1200		
1500		
2000		



GATE

GPPH

WELDING
GATE

GPPH
WELDING
GATE

GPPH

GPPH